

- NOTES:**
- ADDITIONAL GRAVEL SHALL BE ADDED PERIODICALLY TO MAINTAIN PROPER FUNCTION OF THE PAD.
  - RECLAIM THE TEMPORARY CONSTRUCTION ENTRANCE AT THE END OF CONSTRUCTION BY REMOVING ENTRANCE MATERIAL AND GEOTEXTILE (TO BE PROPERLY DISPOSED OF) AND ADD CLEAN PIT RUN OR GRAVEL AS NECESSARY TO RESTORE BACK TO PRE-EXISTING CONDITIONS.

**1 TEMPORARY CONSTRUCTION ENTRANCE**  
NTS

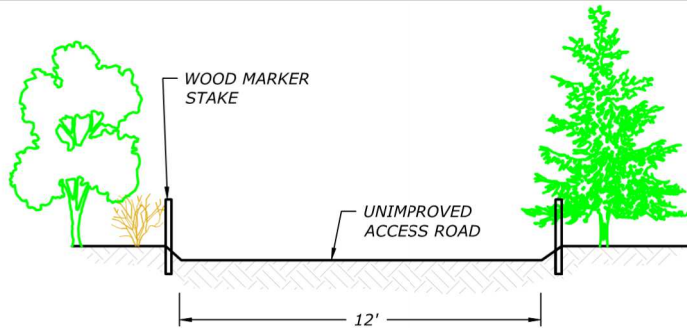

- NOTES:**
- CLEARED ACCESS TO BE ROUTED TO MINIMIZE VEGETATION DISTURBANCE AND EXISTING VEGETATION CLEARING.
  - CONTRACTOR SHALL MARK CLEARING LIMITS. CLEARING LIMITS TO BE APPROVED BY ENGINEER PRIOR TO ANY CLEARING ACTIVITIES.
  - ANY TREES GREATER THAN 18" Ø SHALL BE REMOVED W/ ROOTWADS INTACT AND STOCKPILED FOR USE IN LOGJAM CONSTRUCTION.
  - TREES AND SHRUBS WITH 6"-18" Ø SHALL BE STOCKPILED FOR USE AS RACKING MATERIAL IN LOGJAM CONSTRUCTION.
  - VEGETATION AND ORGANIC SOIL SHALL BE STRIPPED, TEMPORARILY STOCKPILED, AND REPLACED ON ROAD ALIGNMENT AFTER WORK IS COMPLETE AND ACCEPTED.
  - ACCESS SHALL BE MAINTAINED BY MINOR GRADING.
  - RESTORE ACCESS ROADS AND SEED IN ACCORDANCE WITH REVEGETATION PLAN..

**2 CONSTRUCTION ACCESS ROAD**  
NTS

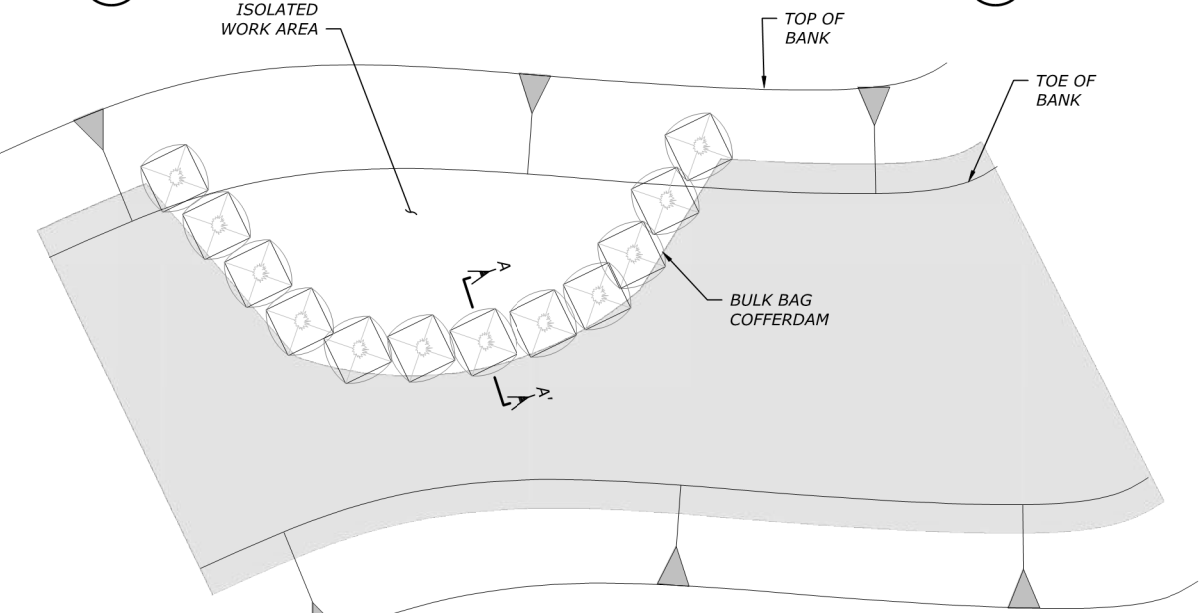

PLAN

- NOTES:**
- SEE SPECIFICATION SECTION XX FOR REQUIREMENTS FOR COFFERDAMS, PUMPING, DEWATERING, AND BACKFILL USED FOR BULK BAGS OR SAND BAG COFFERDAMS.
  - THE CONTRACTOR IS RESPONSIBLE FOR DEVELOPING A COFFERDAM, PUMPING, AND DEWATERING PLAN FOR REVIEW BY THE CONTRACTING OFFICER OR ENGINEER. SEE SPECIFICATION SECTION XX FOR PLAN REQUIREMENTS.
  - WRAP BULK BAGS WITH IMPERVIOUS PLASTIC LINER TO PREVENT SEEPAGE.
  - BACKFILL THE DOWNSTREAM SIDE OF THE COFFERDAM WITH NATIVE ADJACENT ALLUVIUM.
  - USE BULK BAGS AS A BUTTRESS AS REQUIRED.
  - BULK BAG MATERIAL SHALL BE 8 OZ. (MIN) WOVEN FABRIC HAVING A 1200 HOUR UV RESISTANCE WITH LIFTING LOOPS.
  - PLACE BULK BAGS CAREFULLY TO PREVENT TEARING OR CUTTING OF BAGS.
  - BULK BAG FILL MATERIAL SHALL BE CLEAN, WASHED, ALLUVIUM.

**3 BULK BAG COFFERDAM**  
NTS

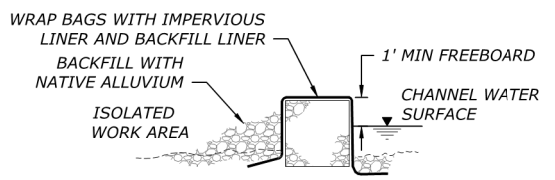

SECTION VIEW (SINGLE BULK BAG)

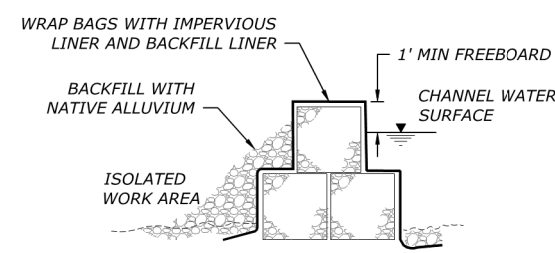

SECTION VIEW (DOUBLE BULK BAG)

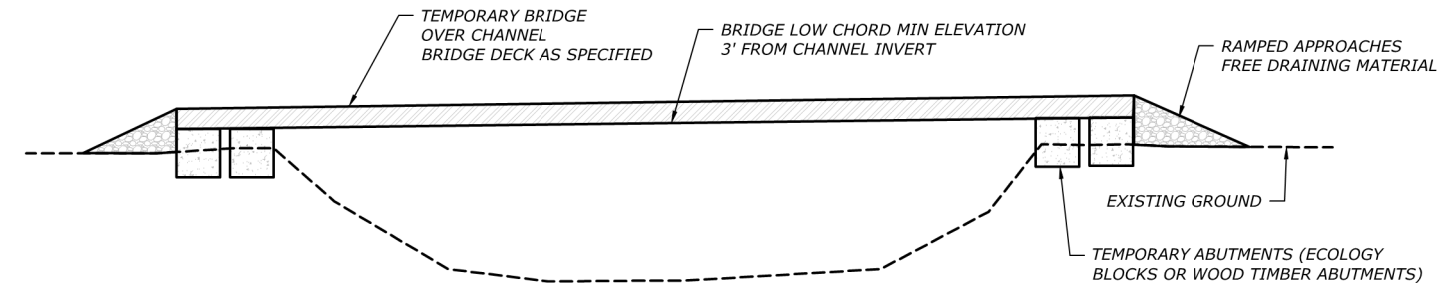

SECTION VIEW

- TEMPORARY BRIDGE NOTES:**
- CONTRACTOR TO DESIGN TEMPORARY BRIDGE FOR CHANNEL CROSSINGS.
  - BRIDGE SHALL BE LOCATED SUCH THAT ONLY ONE SPAN IS USED AT CHANNEL CROSSINGS.
  - END OF BRIDGE SHALL BEAR ON HIGH BANKS WITH SUFFICIENT BEARING CAPACITY TO PREVENT SLOUGHING OR COLLAPSE OF CHANNEL BANKS.
  - CONCRETE ECOLOGY BLOCKS OR WOOD ABUTMENTS MAY BE USED TO SUPPORT ENDS OF TEMPORARY BRIDGE AS NEEDED.
  - BRIDGES MAY BE CONSTRUCTED FROM LOGS, RAIL CAR BEDS OR APPROVED EQUAL AND DECKED WITH STEEL SHEET, WOOD LAGGING OR APPROVED EQUAL.

**4 TEMPORARY BRIDGE**  
NTS

- GENERAL EROSION AND SEDIMENT CONTROL AND WORK AREA ISOLATION NOTES:**
- THE DETAILS SHOWN ON THIS SHEET ARE EXAMPLES OF ACCEPTABLE METHODS TO USE DURING CONSTRUCTION OF THIS PROJECT. THE CONTRACTOR IS RESPONSIBLE FOR DEVELOPING AND SUBMITTING A COFFERDAM, PUMPING, AND DEWATERING PLAN FOR REVIEW AND APPROVAL BY THE CONTRACTING AGENCY OR ENGINEER. THE PLAN SHALL INCLUDE SUFFICIENT DETAIL OF MEANS AND METHODS SATISFYINGLY MEETING THE PROJECT SPECIFICATIONS AND PERMIT REQUIREMENTS. IF APPROVED, OTHER METHODS MAY BE USED SUCH AS UTILIZING INFLATABLE BLADDERS, PLATES, OR BARRIERS OF VARIOUS MATERIALS. COFFERDAMS SHALL INCLUDE PLASTIC LINER OR FINE MESH SILT FENCE TO REDUCE TURBIDITY AND FINES FROM ENTERING THE FREE FLOWING PORTION OF LIVE WATER.
  - COFFERDAMS SHALL BE CONSTRUCTED TO ACCOMMODATE ALL FLOW CONDITIONS AND WATER SURFACE ELEVATIONS EXPECTED DURING CONSTRUCTION PLUS A MINIMUM OF 1-FOOT OF FREEBOARD. THE CONTRACTOR SHALL BE SOLELY AND COMPLETELY RESPONSIBLE FOR COMPLIANCE WITH WATER QUALITY STANDARDS, SAFETY AND CONSTRUCTION STANDARDS, DAMAGE OR LOSS TO EQUIPMENT, MATERIALS, AND DAMAGES TO PRIVATE PROPERTY.
  - THE CONTRACTING AGENCY IS RESPONSIBLE FOR MEASURING TURBIDITY HOWEVER THE CONTRACTOR SHALL ADHERE TO THE SPECIAL PROCEDURES REGARDING IN-STREAM WORK, TURBIDITY, AND DEWATERING (DRAWINGS G2 AND G3). ADDITIONALLY, THIS PROJECT SHALL ADHERE TO HIP CONSERVATION MEASURES. CONSERVATION MEASURES ARE SUMMARIZED ON DRAWINGS G4 - G6 AND SHALL BE STRICTLY ADHERED TO.
  - THE CONTRACTOR SHALL NOTIFY THE OWNER AND CONTRACTING OFFICER AT LEAST 5 DAYS BEFORE EACH COFFERDAM INSTALLATION DATE SO THAT FISH SALVAGE ACTIVITIES CAN BE SCHEDULED. ANTICIPATED COFFERDAM LOCATIONS ARE SHOWN IN THE PLANS.
  - FILL MATERIAL FOR BULK BAGS SHALL BE CLEAN, WASHED, AND ROUNDED MATERIAL MEETING STANDARD SPECIFICATIONS FOR DRAIN ROCK, STREAMBED AGGREGATES, STREAMBED SEDIMENTS, OR STREAMBED COBBLES. MATERIAL USED TO FILL BULK BAGS SHALL BE DISPOSED OF IN ACCORDANCE WITH THE PERMITS.
  - DEWATERING PUMP DISCHARGE FROM WITHIN COFFERDAM WORK AREAS SHALL BE RELEASED ONTO FLOODPLAIN AREAS AWAY FROM WETLANDS AND CONSTRUCTION ACTIVITIES. DISCHARGE SHALL BE COMPLETELY INFILTRATED PRIOR TO REACHING WETLANDS OR SURFACE WATERS UNLESS APPROVED BY THE CONTRACTING OFFICER. ALL RETURN FLOWS MUST MEET PERMIT REQUIREMENTS FOR TURBIDITY.
  - EXCAVATIONS ASSOCIATED WITH CHANNEL, FLOODPLAIN, AND WOOD HABITAT STRUCTURES SHALL BE DEWATERED IN ACCORDANCE WITH THE SPECIFICATIONS.
  - ALL PUMP INTAKES SHALL BE SCREENED FOR FISH PROTECTION AS REQUIRED BY NOAA.
  - ALL EARTHWORK ACTIVITIES AND WOOD HABITAT STRUCTURE CONSTRUCTION WITHIN THE ORDINARY HIGH WATER CHANNEL SHALL CONFORM TO THE WATER QUALITY STANDARDS ESTABLISHED BY REGULATORY AGENCY PERMITS FOR THIS PROJECT.



CHESNIMNUS CREEK - WILLIAMS  
RESTORATION DESIGN  
DRAFT 80% DESIGN DRAWINGS  
FOR NEZ PERCE TRIBE  
CHESNIMNUS CREEK, GRANDE RONDE RIVER BASIN, OREGON  
WALLOWA COUNTY, OREGON

**WORKING DRAFT  
FOR REVIEW AND  
REVISION**

DATE: JULY, 2025  
DESIGNED: MP, IB, JE, ZS, SB  
APPROVED: JE

DRAWING NAME  
DETAILS  
ACCESS & EROSION  
CONTROL DETAILS

DRAWING NO.  
D1  
SHEET 75 OF 94

FILE: R:\PROJECTS\LOWER GRANDE RONDE\_HUC65\CHESNIMNUS\_CREEK\_NPT\CAD\PRODUCTION\CHESNIMNUS-NPT-DETAILS.DWG SAVED BY: SAM.BOX PLOT DATE: 7/30/2025 7:15 PM

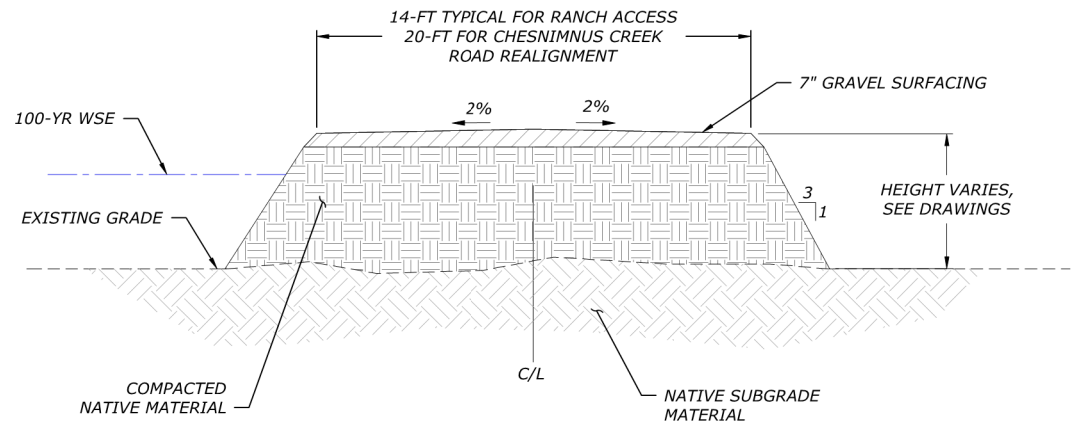

**5** GRAVEL ROAD TYPICAL SECTION  
NTS

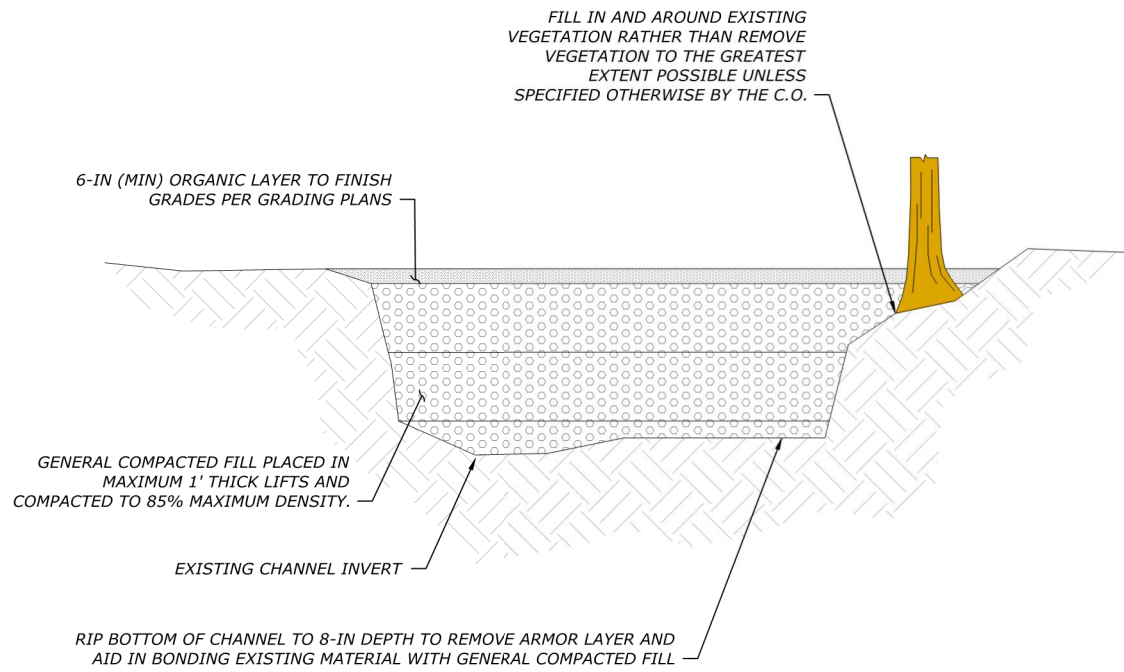

**6** TYPICAL CHANNEL FILL  
NTS

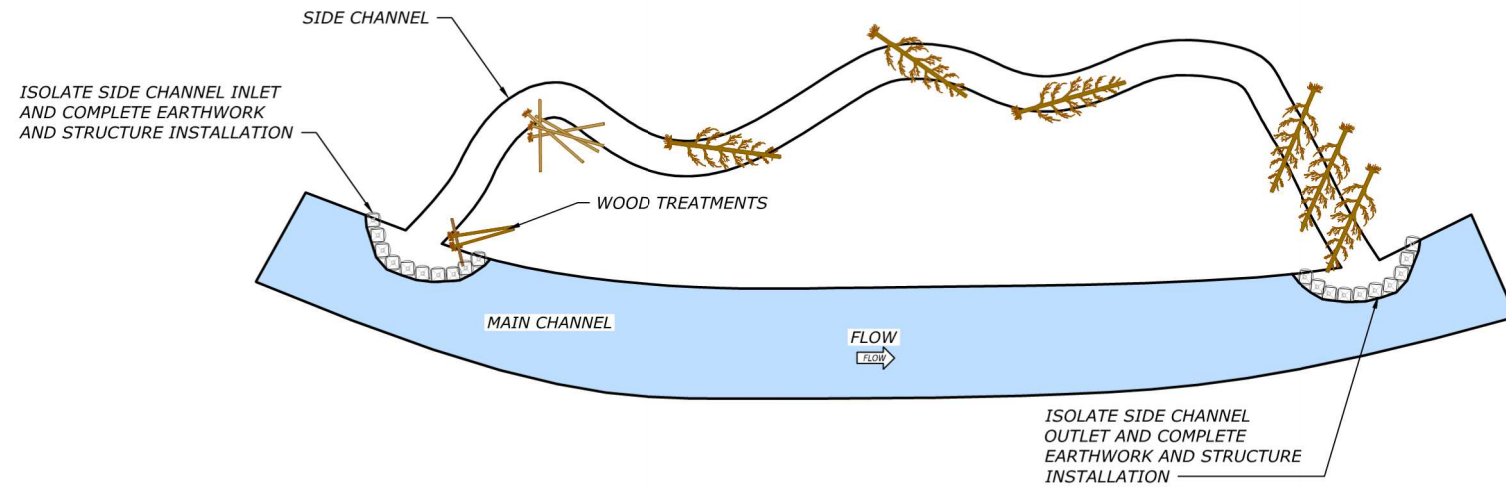
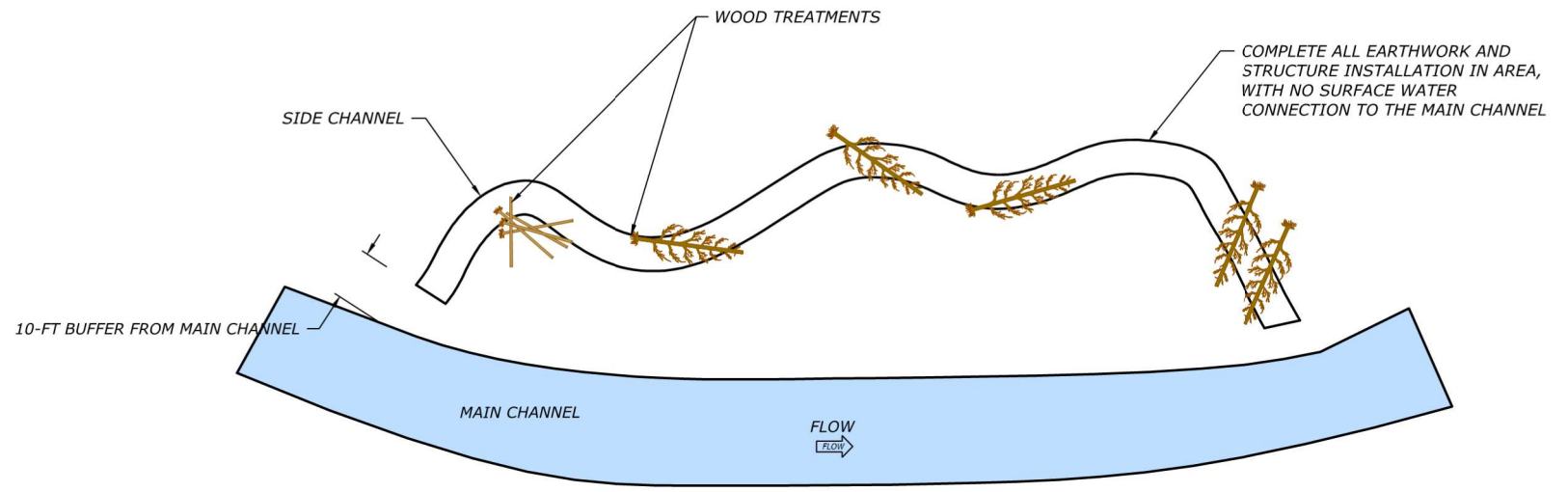

ISOLATE SIDE CHANNEL  
OUTLET AND COMPLETE  
EARTHWORK AND STRUCTURE  
INSTALLATION

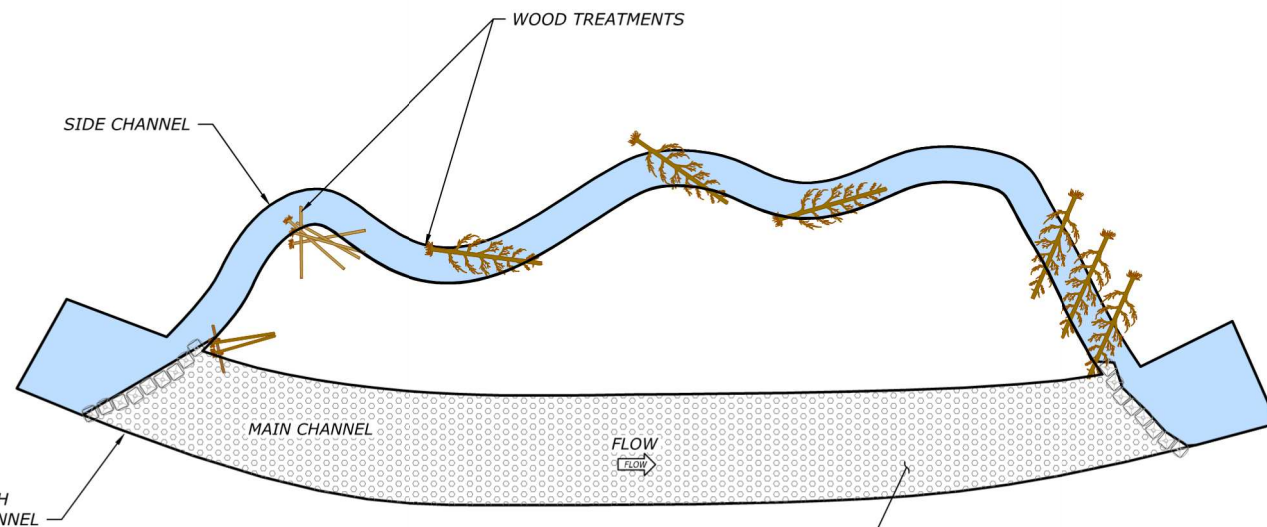

AFTER ISOLATION AND FISH SALVAGE HAVE OCCURRED,  
BACKFILL MAIN CHANNEL TO REACH FINISH GRADE, THEN PREP  
SEED BED AND REVEGETATE ACCORDING TO DRAWING L1

**7** TYPICAL SEQUENCING  
NTS



CHESNIMNUS CREEK - WILLIAMS  
RESTORATION DESIGN  
DRAFT 80% DESIGN DRAWINGS

FOR NEZ PERCE TRIBE  
CHESNIMNUS CREEK, GRANDE RONDE RIVER BASIN, OREGON  
WALLOWA COUNTY, OREGON

**WORKING DRAFT  
FOR REVIEW AND  
REVISION**

DATE: JULY, 2025  
DESIGNED: MP, IB, JF, ZS, SB  
APPROVED: JF

DRAWING NAME  
DETAILS

CHANNEL FILL AND  
SEQUENCING

DRAWING NO.  
D2  
SHEET 76 OF 94

FILE: R:\PROJECTS\LOWER GRANDE RONDE\HUC65\CHESNIMNUS CREEK\NTD\CAD\PRODUCTION\CHESNIMNUS-NTD-DETAILS.DWG, SAVES BY: SAM.BOX, PLOT DATE: 7/30/2025 7:15 PM

**RIFFLE OVERVIEW NOTES:**

CONSTRUCTED RIFFLES ARE TO BE INSTALLED AT LOCATIONS SHOWN IN THE GRADING PLANS. CONSTRUCTED RIFFLES SHALL BE OVER EXCAVATED AND REPLACED UNLESS DIRECTED BY ENGINEER.

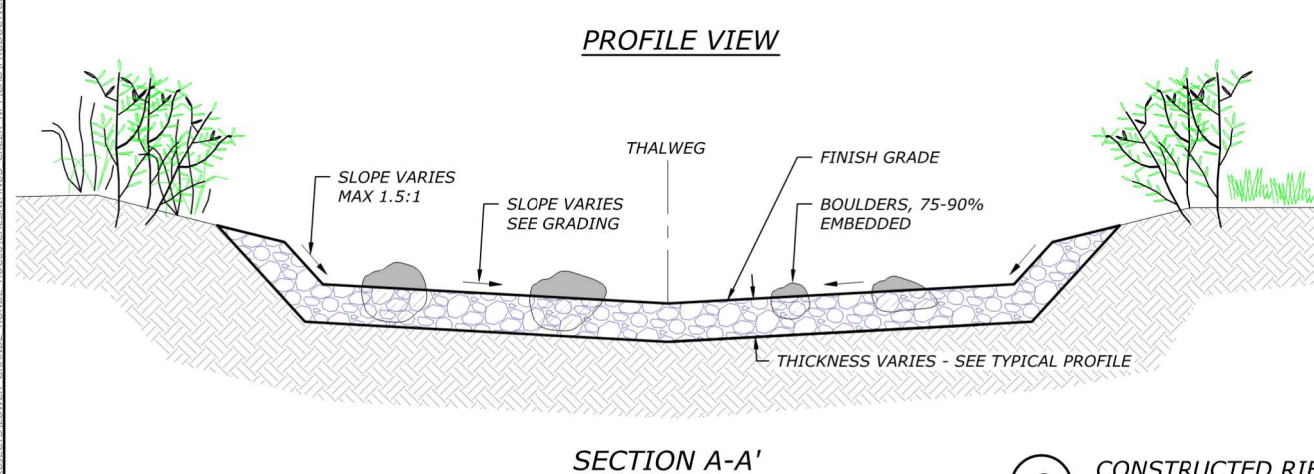
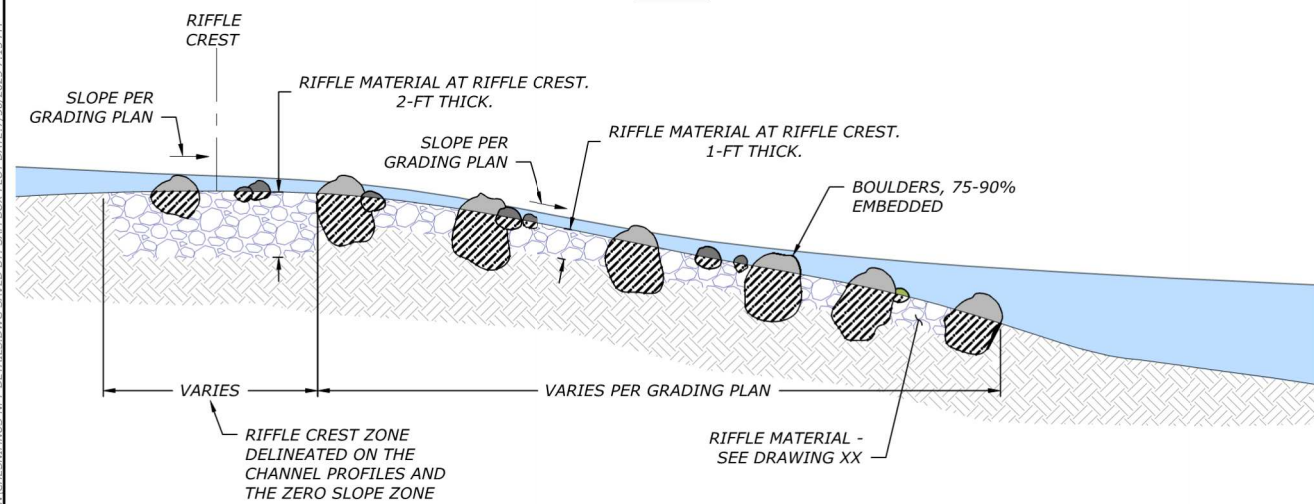
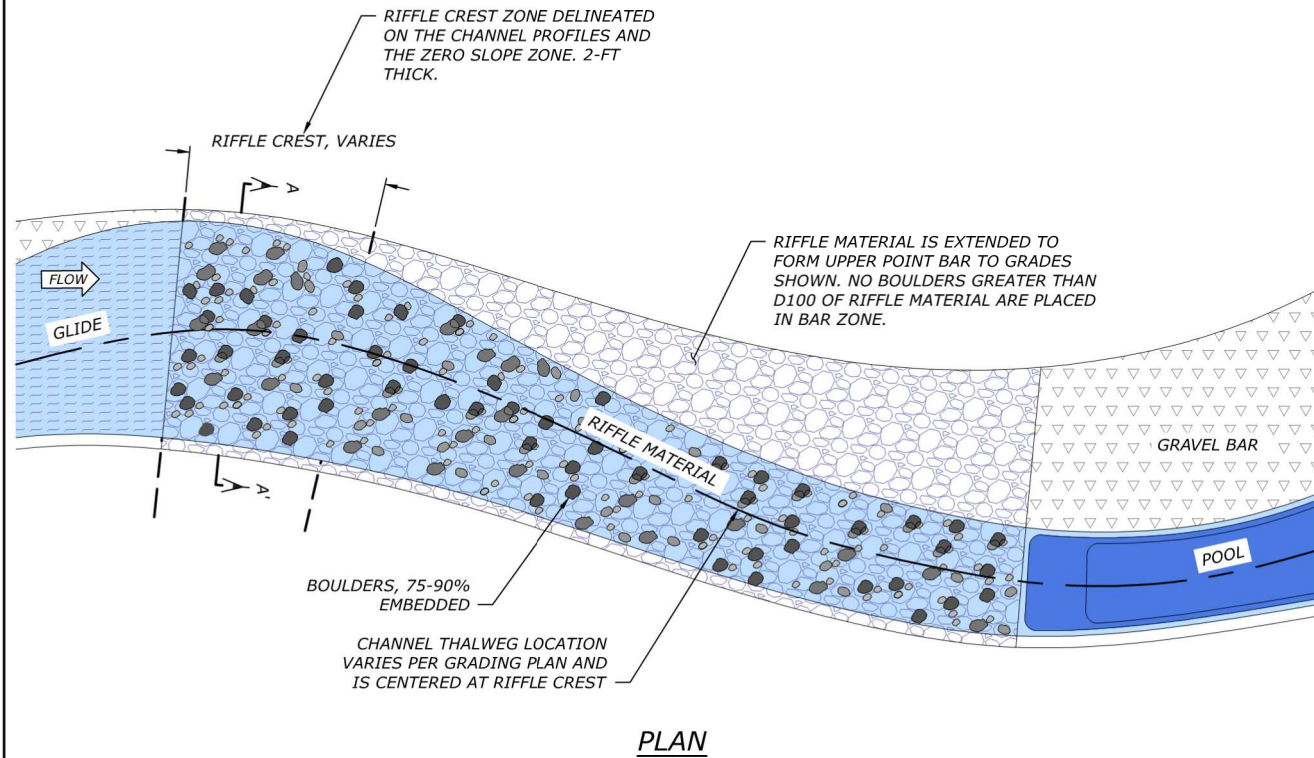

**CONSTRUCTION SEQUENCING**

**STAGE 1 - ROUGH GRADE**

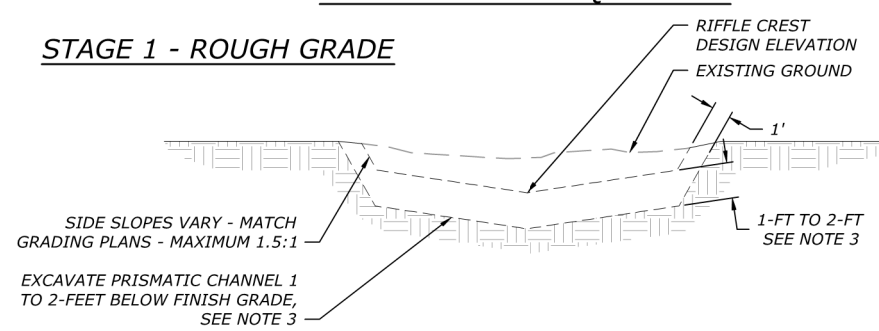

**STAGE 2 - FIRST LIFT\***

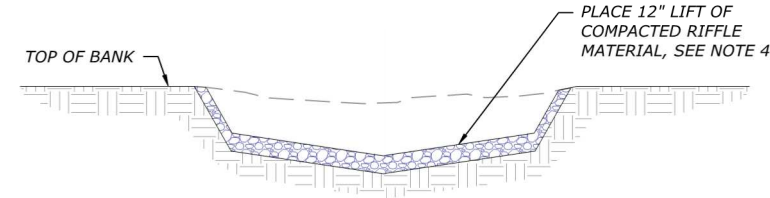

**STAGE 3 - SECOND LIFT\***

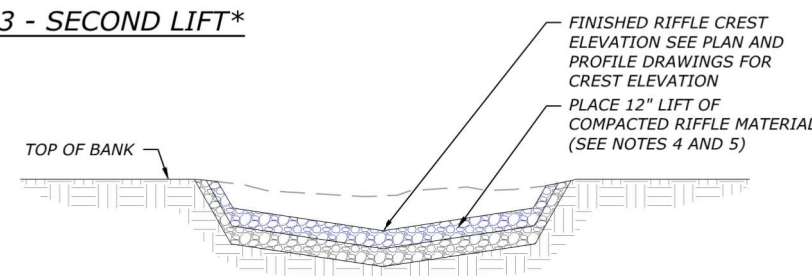

**STAGE 4 - BOULDER PLACEMENT, BANK TREATMENT, AND TOP DRESSING**

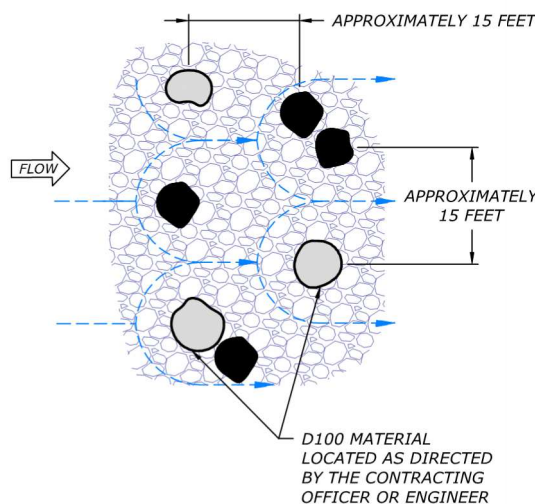
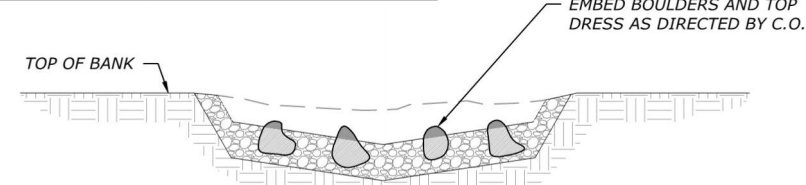

**BOULDER PLACEMENT**

**CONSTRUCTED RIFFLE NOTES:**

- STOCKPILE CHANNEL MATERIALS PER DESIGN SPECIFICATIONS. MATERIALS ARE TO BE STOCKPILED IN THE IMMEDIATE PROJECT AREA OR TRANSPORTED FROM THE SORTING AREA AS NEEDED.
- THREE PLACEMENTS ARE REQUIRED AS FOLLOWS:
  - CONSTRUCTED RIFFLE MATERIAL
  - LARGE AND SMALL BOULDERS (FOR EMBEDMENT)
  - ROUGHNESS ROCK (TOP DRESSING)
- TREAT EXISTING CHANNEL BED BY REMOVING ORGANICS AND CREATING A PRISMATIC WORKING SURFACE FOLLOWING CHANNEL THALWEG AND DESIGN CONTOURS ON GRADING DRAWINGS. ROUGH GRADE FROM FINISH GRADE TO SPECIFIED RIFFLE MATERIAL DEPTH IN CHANNEL BED IN ACCORDANCE WITH PLAN AND PROFILE DRAWINGS. ROUGH GRADE BANKS BY 1-FT TO SLOPES SHOWN ON GRADING PLANS AND NOT EXCEEDING 1.5:1.
- RIP EXISTING CHANNEL BED AT MINIMUM 4" DEEP TO CREATE A BETTER BONDING SURFACE BETWEEN THE TWO LAYERS.
- IMPORT WELL-MIXED RIFFLE MATERIAL AND/OR CREATE MATERIAL FROM NATIVE ALLUVIUM FROM PROJECT EXCAVATIONS MEETING THE SPECIFICATIONS FOR CONSTRUCTED RIFFLE MATERIAL. COMPACT RIFFLE MATERIAL IN 12-INCH LIFTS USING TRACKED 300 SERIES EXCAVATOR, OR SIMILAR EQUIPMENT AS APPROVED BY C.O. TRACK ON MATRIX MATERIAL SUFFICIENTLY TO COMPACT MATERIAL.
- REPEAT RIFFLE CONSTRUCTION BY PLACING ANOTHER 12-INCH LIFT WHERE REQUIRED TO MEET DESIGN GRADE AND CROSS SECTION SHAPE.
- BOULDERS OF VARIOUS SIZES (LARGE AND SMALL - SEE RIFFLE MATERIALS DRAWING, DRAWING XX) ARE TO BE ADDED TO THE RIFFLE TO CREATE DIVERSE FLOW PATHS AND HABITAT, SEE BOULDER PLACEMENT THIS SHEET.
- TOP DRESS WITH COARSE RIFFLE MATERIAL AS NEEDED AND DIRECTED BY C.O. TO ADD SOME INITIAL ROUGHNESS TO THE CHANNEL AND FORM A NATURAL APPEARANCE.
- FOR THOSE AREAS WHERE HABITAT STRUCTURES OR BANK TREATMENTS ARE TO BE PLACED ADJACENT TO THE CONSTRUCTED RIFFLE, THE RIFFLE WILL BE CONSTRUCTED BEFORE PLACEMENT OF ADJACENT FEATURES.
- COMPLETED RIFFLES OR CHANNELS (APPROVED BY THE ENGINEER OR CONTRACTING OFFICER) SHALL BE LEFT UNDISTURBED (NOT DRIVEN ON BY MACHINERY) UNLESS APPROVED BY THE CONTRACTING OFFICER..



CHESNIMNUS CREEK - WILLIAMS RESTORATION DESIGN  
DRAFT 80% DESIGN DRAWINGS

FOR NEZ PERCE TRIBE  
CHESNIMNUS CREEK, GRANDE RONDE RIVER BASIN, OREGON  
WALLOWA COUNTY, OREGON

**WORKING DRAFT FOR REVIEW AND REVISION**

DATE: JULY, 2025  
DESIGNED: MP, IB, JF, ZS, SB  
APPROVED: JF

DRAWING NAME  
DETAILS

CONSTRUCTED RIFFLE

DRAWING NO.  
D3  
SHEET 77 OF 94

WORKING DRAFT  
 FOR REVIEW AND  
 REVISION

DATE: JULY, 2025  
 DESIGNED: MP, IB, JE, ZS, SB  
 APPROVED: JE

DRAWING NAME  
DETAILS

HS-1 - THREE-LOG STRUCTURE

DRAWING NO.  
**D4**  
SHEET 78 OF 94

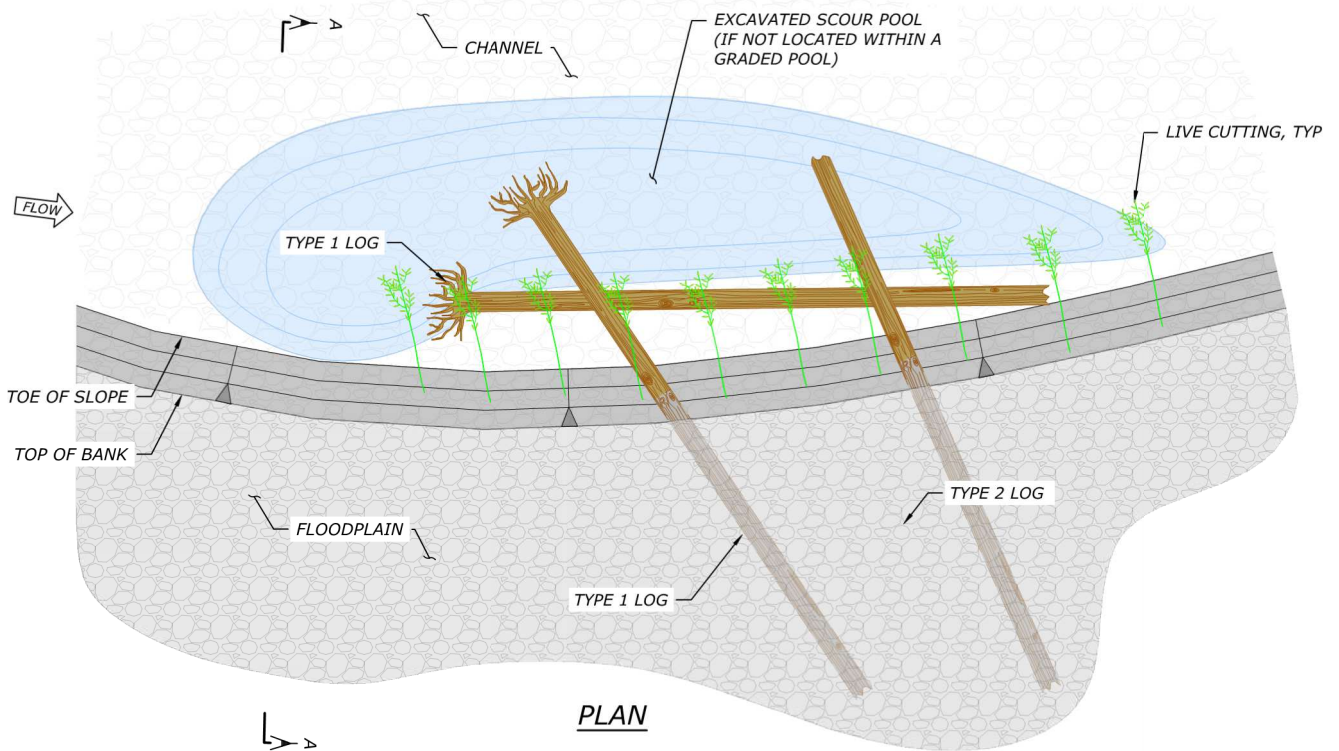

**PLAN**

NOTE: RACKING AND SLASH MATERIAL NOT SHOWN IN PLAN AND SECTION DETAILS FOR CLARITY.

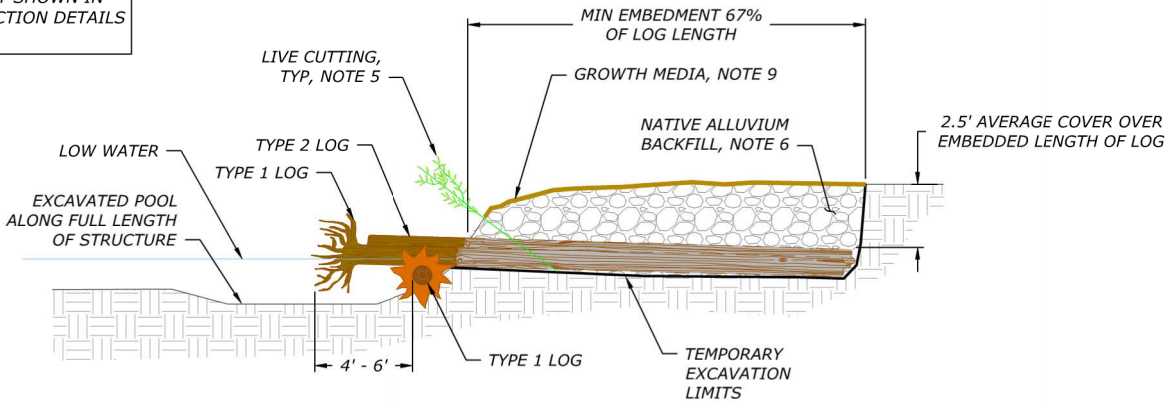

**SECTION A-A'**

**NOTES:**

1. INSTALL STRUCTURES AT LOCATIONS IDENTIFIED IN THE PLANS. THE EXACT LOCATION OF EACH STRUCTURE SHALL BE APPROVED BY THE CONTRACTING OFFICER PRIOR TO INSTALLATION.
2. IF POOL EXCAVATION IS NOT SPECIFIED IN THE GRADING PLAN, THE CONTRACTING OFFICER WILL DETERMINE IF A SCOUR POOL IS DESIRED. THE SCOUR POOL SHALL BE EXCAVATED TO A DEPTH OF 2' ADJACENT TO THE STRUCTURE AND EXTEND BEYOND ROOTWADS EXTENDING INTO CHANNEL PER THE DIRECTION OF THE CONTRACTING OFFICER.
3. ROUGH GRADING OF CHANNEL SHALL BE COMPLETE PRIOR TO CONSTRUCTION OF STRUCTURE INCLUDING CONSTRUCTION OF RIFFLES OR STREAMBED MATERIALS.
4. RACKING, SLASH, AND LIVE STAKES SHALL BE INCORPORATED INTO THE STRUCTURE BY WEAVING THE MATERIAL IN BETWEEN PLACED LOGS, FILLING VOIDS, ETC. AT EACH STEP THROUGHOUT CONSTRUCTION AS DIRECTED BY THE CONTRACTING OFFICER. RACKING CAN BE PLACED FIRST TO LIFT THE LOG OFF CHANNEL BED AS DIRECTED BY THE CONTRACTING OFFICER. SEE STRUCTURE SEQUENCING FOR RACKING AND SLASH PLACEMENT.
5. LIVE STAKES SHALL BE INSTALLED PRIOR TO AND/OR DURING BACKFILLING TO ENSURE A MINIMUM OF 1-FT SUBMERGENCE IN GROUND WATER. LIVE STAKES SHALL HAVE CONTINUOUS CONTACT WITH SOIL ALONG THE LENGTH OF THE STAKE LEAVING NO VOIDS.
6. BACKFILL USING NATIVE EXCAVATED MATERIAL UNLESS NATIVE MATERIAL IS UNSUITABLE. UNSUITABLE IS DEFINED AS ANYTHING CLASSIFIED AS A CLAY, SILT, OR SAND. PLACE BACKFILL IN 1-FOOT MAXIMUM LIFTS. COMPACT EACH LIFT USING MECHANICAL EQUIPMENT SUCH AS AN EXCAVATOR BUCKET OR EQUIPMENT TRACKING MAKING CERTAIN TO NOT DAMAGE OR CHANGE THE ELEVATION OF THE STRUCTURE MATERIAL DURING COMPACTION.
7. ALL CUT ENDS OF LOGS THAT WILL BE EXPOSED UPON COMPLETION OF STRUCTURE SHALL BE MARRED PRIOR TO INSTALLATION. THE CONTRACTOR SHALL USE AN EXCAVATOR, OR OTHER HEAVY EQUIPMENT TO TEAR APART WOOD FIBERS AT THE CUT END OF THE LOG TO CREATE THE APPEARANCE OF A LOG THAT HAS NATURALLY BROKEN APART.
8. LOG PLACEMENT MAY BE ADJUSTED IN THE FIELD BY THE CONTRACTING OFFICER TO PROVIDE VARIABILITY FROM STRUCTURE TO STRUCTURE.
9. SEE DRAWING L1 AND SPECIFICATIONS FOR PLANTING AND SEEDING REQUIREMENTS.

**THREE-LOG STRUCTURE MATERIAL SCHEDULE**

LOG TYPE	DIAMETER (IN)	LENGTH (FT)	ROOTWAD	MIN ROOTWAD DIAMETER (FT)	BRANCHES	QUANTITY/STRUCTURE
TYPE 1	13" - 22"	30 - 40	YES	4.5	NO	2 EA
TYPE 2	13" - 22"	30 - 40	NO	NA	NO	1 EA
RACKING - 1	4" - 12"	15 - 25	YES	2.5	YES	3 EA
RACKING - 2	4" - 12"	15 - 25	OPTIONAL	NA	YES	3 EA
SLASH	1" - 4"	5 - 15	NA	NA	YES	8 CY
LIVE CUTTINGS	> 3/4"	6 - 8	NA	NA	NO	15 EA

1. IF LIVE CUTTINGS QUANTITY IS FOR DORMANT INSTALLATION, QUANTITY SHALL BE DOUBLED IF INSTALLED APRIL 21 TO OCTOBER 10.

**STRUCTURE SEQUENCING**

**STAGE 1**

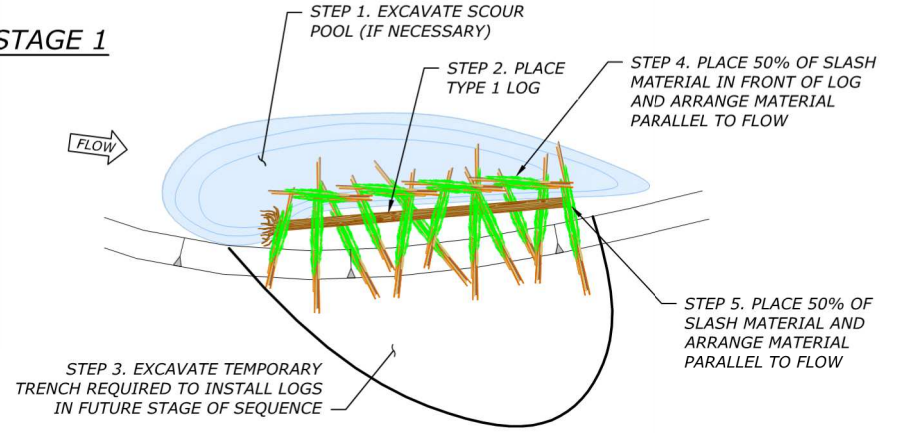

**STAGE 2**

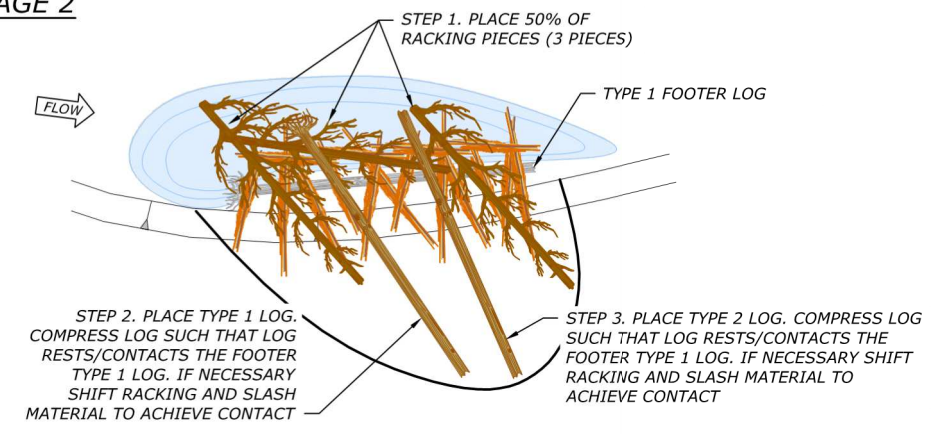

**STAGE 3**

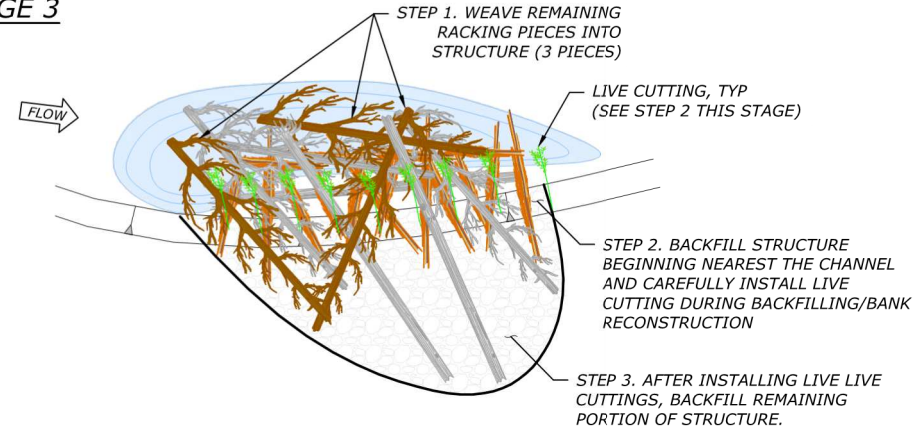

**9 HABITAT STRUCTURE - 1 (HS-1) THREE-LOG STRUCTURE**  
NTS

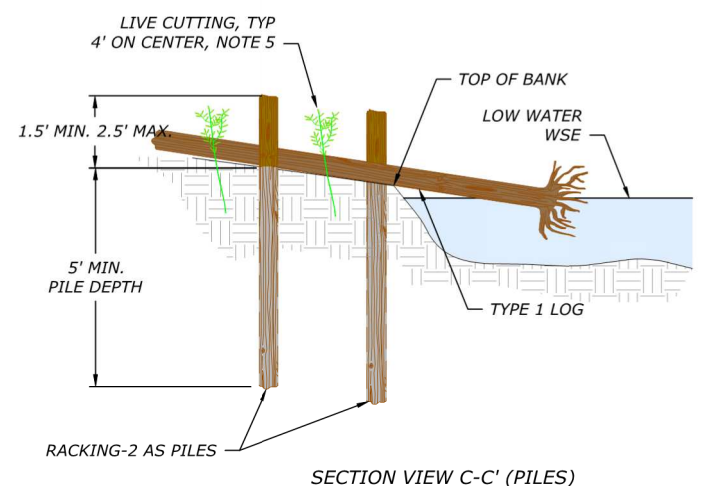
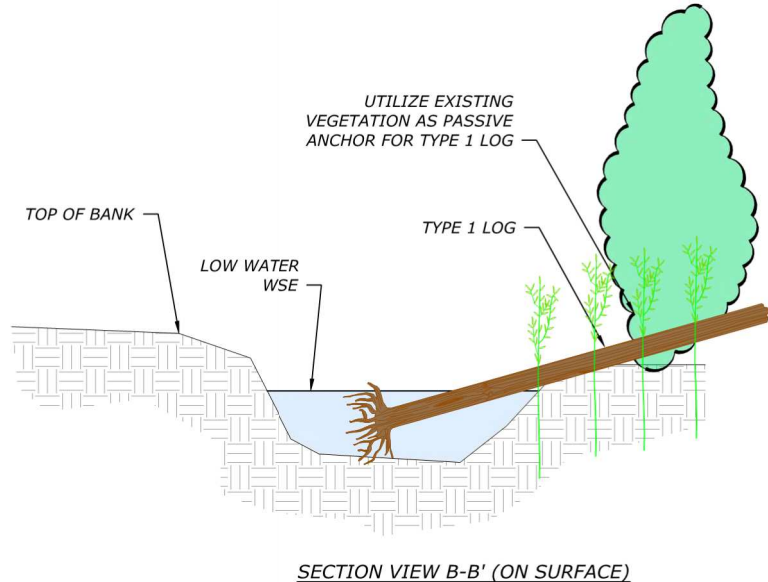
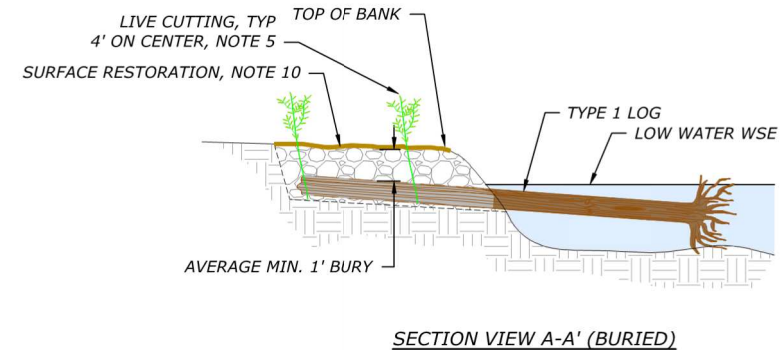
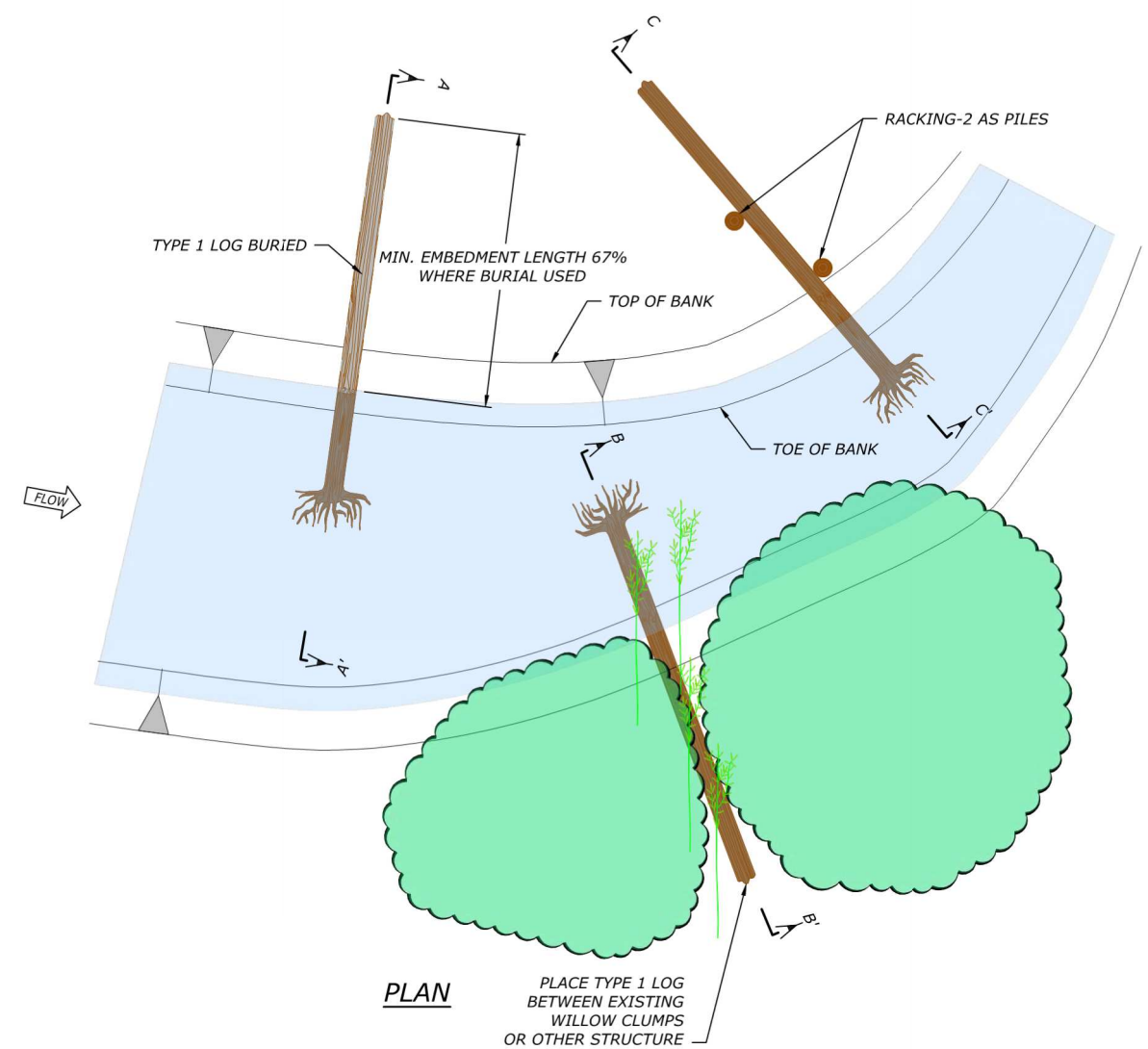

**NOTES:**

1. INSTALL STRUCTURES AT LOCATIONS IDENTIFIED ON PLAN AND PROFILE DRAWINGS.
2. THE EXACT LOCATION OF EACH STRUCTURE SHALL BE LOCATED PRIOR TO INSTALLATION FOR APPROVAL BY THE CONTRACTING OFFICER.
3. ROUGH GRADING OF CHANNEL SHALL BE COMPLETE PRIOR TO CONSTRUCTION OF STRUCTURE INCLUDING RIFFLE CONSTRUCTION AND PLACEMENT OF BAR MATERIAL.
4. SEE STRUCTURE SCHEDULE FOR NUMBER OF STRUCTURES, LOCATIONS, LOGS, AND ASSOCIATED MATERIAL QUANTITIES.
5. ALL CUT ENDS OF LOGS THAT WILL BE EXPOSED UPON COMPLETION OF STRUCTURE SHALL BE MARRED PRIOR TO INSTALLATION. THE CONTRACTOR SHALL USE AN EXCAVATOR, OR OTHER HEAVY EQUIPMENT TO TEAR APART WOOD FIBERS AT THE CUT END OF THE LOG TO CREATE THE APPEARANCE OF A LOG THAT HAS NATURALLY BROKEN APART.
6. RACKING AND SLASH SHALL BE INCORPORATED INTO THE STRUCTURE BY PINNING BENEATH THE TYPE 1 LOG AS DIRECTED BY THE CONTRACTING OFFICER.
7. WHEN BURIED, BACKFILL USING NATIVE EXCAVATED MATERIAL UNLESS NATIVE MATERIAL IS UNSUITABLE FOR BACKFILL. PLACE BACKFILL IN 1-FOOT MAXIMUM LIFTS. COMPACT EACH LIFT USING MECHANICAL EQUIPMENT SUCH AS AN EXCAVATOR BUCKET OR EQUIPMENT TRACKING.
8. WHEN UTILIZING EXISTING VEGETATION AS PASSIVE ANCHORS THERE SHALL BE AT A MINIMUM A WILLOW CLUMP ON THE DOWNSTREAM SIDE, BUT PREFERABLY ON THE UPSTREAM SIDE AS WELL. THE CONTRACTING OFFICER SHALL AGREE TO PLACEMENT AREAS OF STRUCTURES THAT ARE NOT BURIED.
9. LOG PLACEMENT MAY BE ADJUSTED IN THE FIELD BY THE CONTRACTING OFFICER TO PROVIDE VARIABILITY FROM STRUCTURE TO STRUCTURE.
10. SEE DRAWING L1 AND SPECIFICATIONS FOR PLANTING AND SEEDING REQUIREMENTS.

SINGLE LOG STRUCTURE MATERIAL SCHEDULE						
LOG TYPE	SIZE (DBH)	LENGTH (FT)	ROOTWAD	MIN ROOTWAD DIAMETER (FT)	BRANCHES	QUANTITY
TYPE 1	13" - 22"	30 - 40	YES	4.5	NO	1 EA
RACKING - 2	4" - 12"	15 - 25	OPTIONAL	NA	YES	3 EA
SLASH	1" - 4"	5 - 15	NA	NA	YES	3 CY
LIVE CUTTINGS	> 3/4"	6 - 8	NA	NA	NO	6 EA

1. IF LIVE CUTTINGS QUANTITY IS FOR DORMANT INSTALLATION, QUANTITY SHALL BE DOUBLED IF INSTALLED APRIL 21 TO OCTOBER 10.

WORKING DRAFT  
 FOR REVIEW AND  
 REVISION

DATE: JULY, 2025  
 DESIGNED: MP, IB, JE, ZS, SB  
 APPROVED: JE

DRAWING NAME  
 DETAILS

HS-2 - SINGLE LOG  
 STRUCTURE

DRAWING NO.  
 D5  
 SHEET 79 OF 94

FILE: R:\PROJECTS\LOWER GRANDE RONDE\_HUC65\CHESNIMNUS CREEK\_NPT\CAD\PRODUCTION\CHESNIMNUS-NPT-DETAILS.DWG SAVED BY: SAM.BOX PLOT DATE: 7/30/2025 7:15 PM

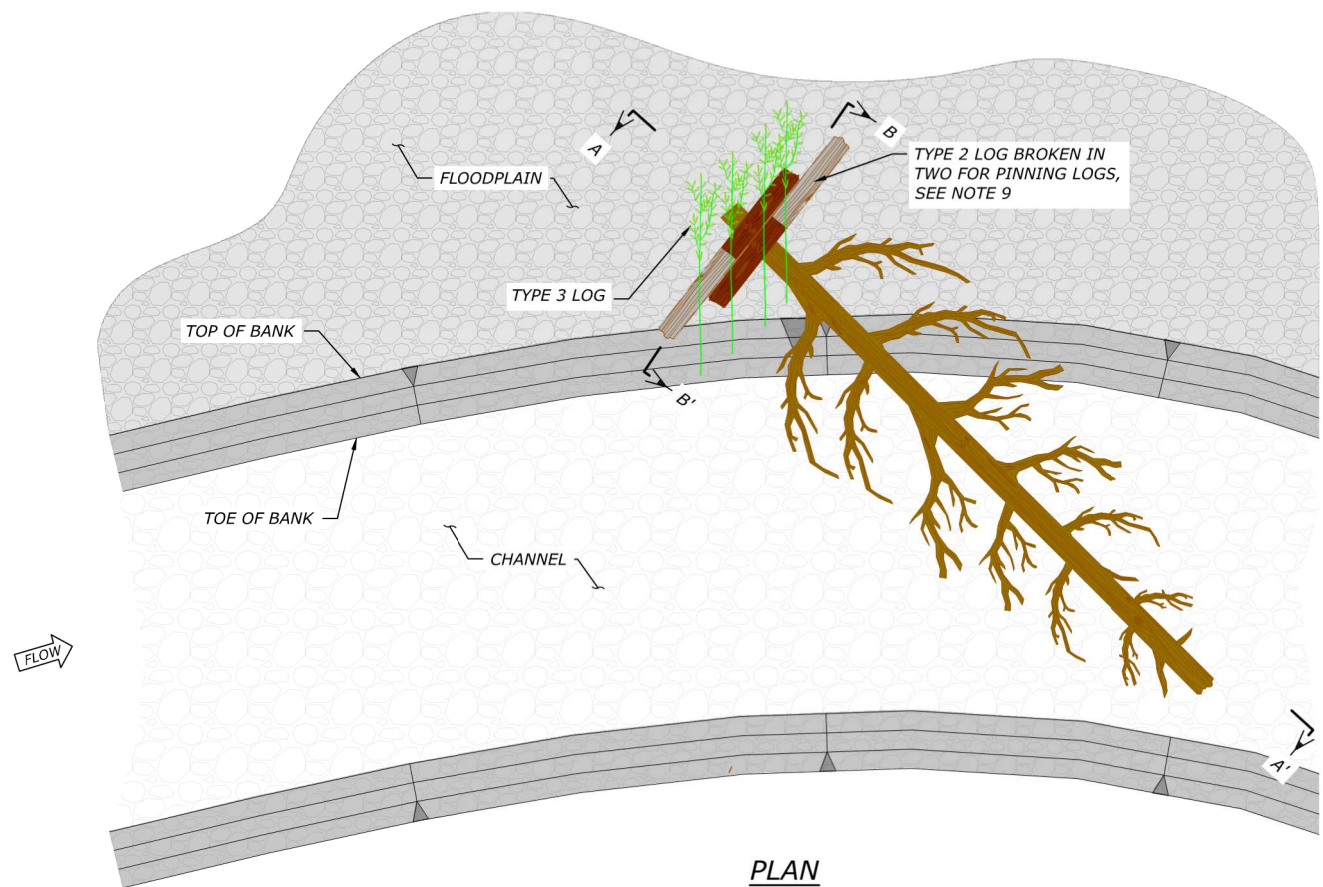

PLAN

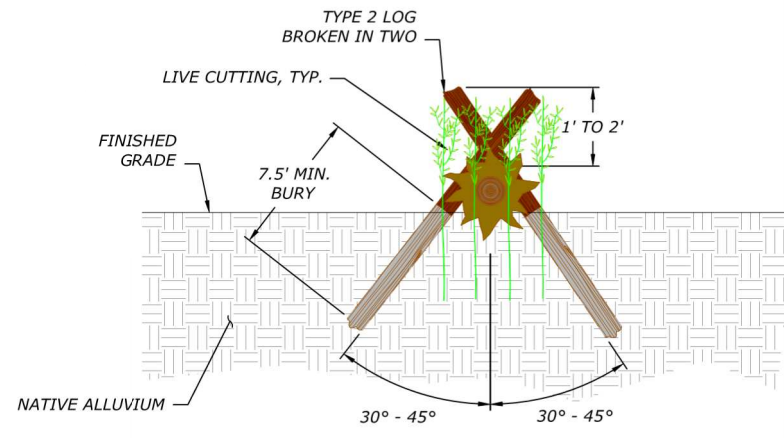

SECTION B-B'

- NOTES:**
1. ALL CUT ENDS OF LOGS THAT WILL BE EXPOSED UPON COMPLETION OF STRUCTURE SHALL BE MARRED. THE CONTRACTOR SHALL USE AN EXCAVATOR, OR OTHER HEAVY EQUIPMENT TO TEAR APART WOOD FIBERS AT THE CUT END OF THE LOG TO CREATE THE APPEARANCE OF A LOG THAT HAS NATURALLY BROKEN APART.

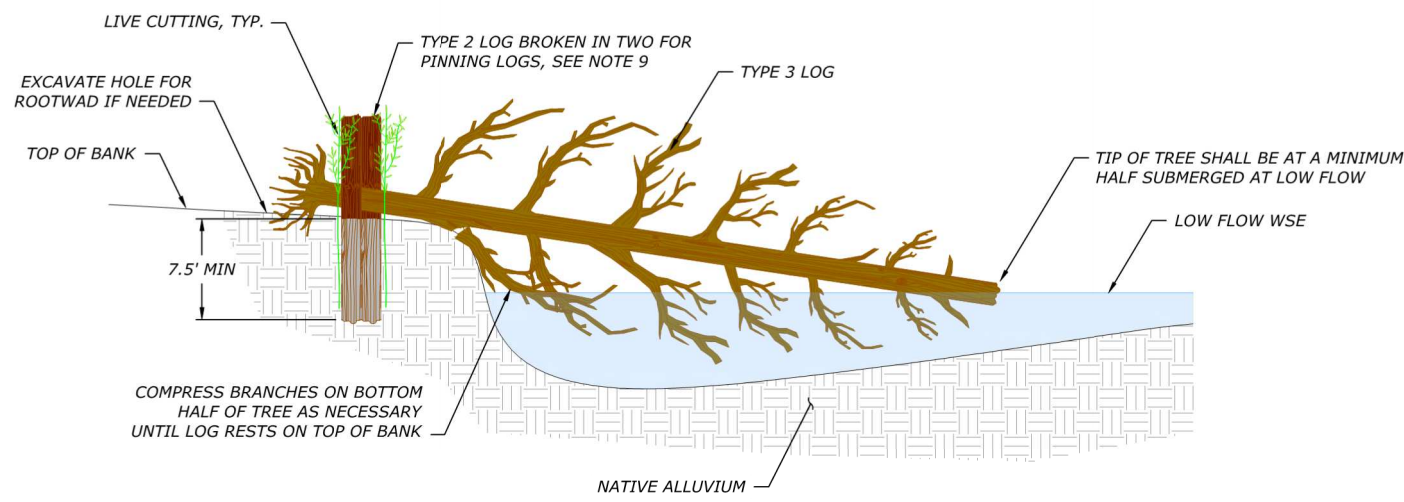

SECTION A-A'

- NOTES:**
1. INSTALL STRUCTURES AT LOCATIONS IDENTIFIED IN THE PLANS. THE EXACT LOCATION OF EACH STRUCTURE SHALL BE LOCATED PRIOR TO INSTALLATION FOR APPROVAL BY THE CONTRACTING OFFICER.
  2. ROUGH GRADING OF CHANNEL SHALL BE COMPLETE PRIOR TO CONSTRUCTION OF STRUCTURE INCLUDING RIFFLE CONSTRUCTION AND PLACEMENT OF BAR MATERIAL.
  3. ALL CUT ENDS OF LOGS THAT WILL BE EXPOSED UPON COMPLETION OF STRUCTURE SHALL BE MARRED PRIOR TO INSTALLATION. THE CONTRACTOR SHALL USE AN EXCAVATOR, OR OTHER HEAVY EQUIPMENT TO TEAR APART WOOD FIBERS AT THE CUT END OF THE LOG TO CREATE THE APPEARANCE OF A LOG THAT HAS NATURALLY BROKEN APART.
  4. TYPE 3 LOG SHALL BE HANDLED A MINIMUM NUMBER OF TIMES TO REDUCE LOSS OF LIMBS, FOLIAGE, ETC.. IF MORE THAN 15% OF TREE BRANCHES ARE REMOVED OR DAMAGED DURING HANDLING THE CONTRACTOR SHALL REPLACE AT NO COST TO THE SPONSOR.
  5. SLASH MATERIAL SHALL BE INCORPORATED INTO THE STRUCTURE BY PLACING IT UPSTREAM OR UNDER TYPE 3 LOG, AS DIRECTED BY THE CONTRACTING OFFICER. LOG PLACEMENT MAY BE ADJUSTED IN THE FIELD BY THE CONTRACTING OFFICER TO PROVIDE VARIABILITY FROM STRUCTURE TO STRUCTURE.
  7. PINNING LOGS TO BE DRIVEN.

WHOLE TREE STRUCTURE MATERIAL SCHEDULE						
LOG TYPE	SIZE (DBH)	LENGTH (FT)	ROOTWAD	MIN ROOTWAD DIAMETER (FT)	BRANCHES	QUANTITY
TYPE 3	13" - 22"	40 - 60	YES	4	YES	1 EA
RACKING - 2	4" - 12"	15 - 25	OPTIONAL	NA	YES	2 EA
SLASH	1" - 4"	5 - 15	NA	NA	YES	5 CY
LIVE CUTTINGS	> 3/4"	6 - 8	NA	NA	NO	6 EA

1. IF LIVE CUTTINGS QUANTITY IS FOR DORMANT INSTALLATION, QUANTITY SHALL BE DOUBLED IF INSTALLED APRIL 21 TO OCTOBER 10.

**WORKING DRAFT  
FOR REVIEW AND  
REVISION**

DATE: JULY, 2025  
DESIGNED: MP, IB, JF, ZS, SB  
APPROVED: JF

DRAWING NAME  
DETAILS

HS-3 - WHOLE TREE  
STRUCTURE

DRAWING NO.  
D6  
SHEET 80 OF 94

FILE: R:\PROJECTS\LOWER GRANDE RONDE\_HUC65\CHESNIMNUS\_CREEK\_NPT\CAD\PRODUCTION\CHESNIMNUS\_NPT-DETAILS.DWG SAVED BY: SAM.BOX PLOT DATE: 7/30/2025 7:24 PM

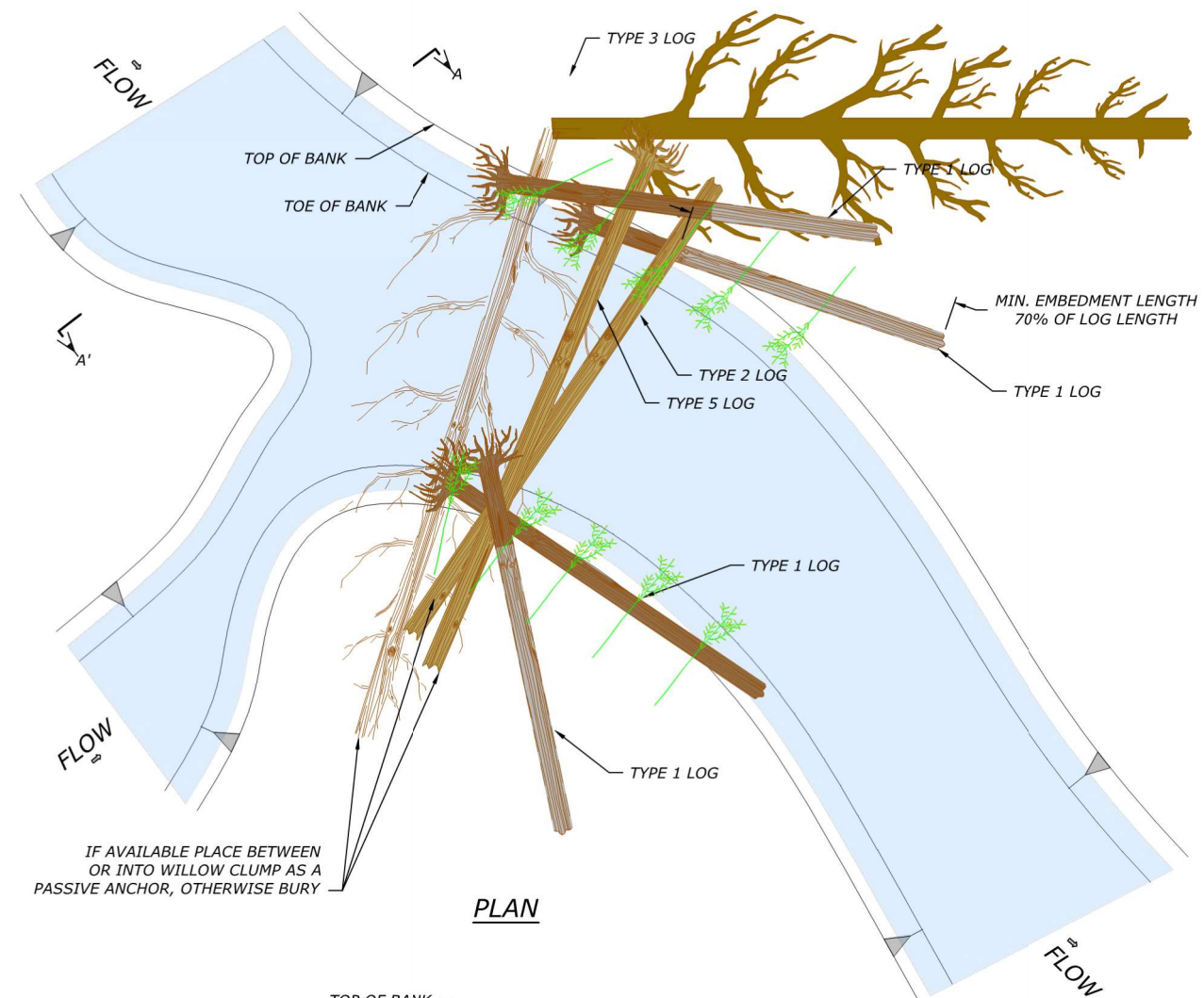

IF AVAILABLE PLACE BETWEEN OR INTO WILLOW CLUMP AS A PASSIVE ANCHOR, OTHERWISE BURY

**PLAN**

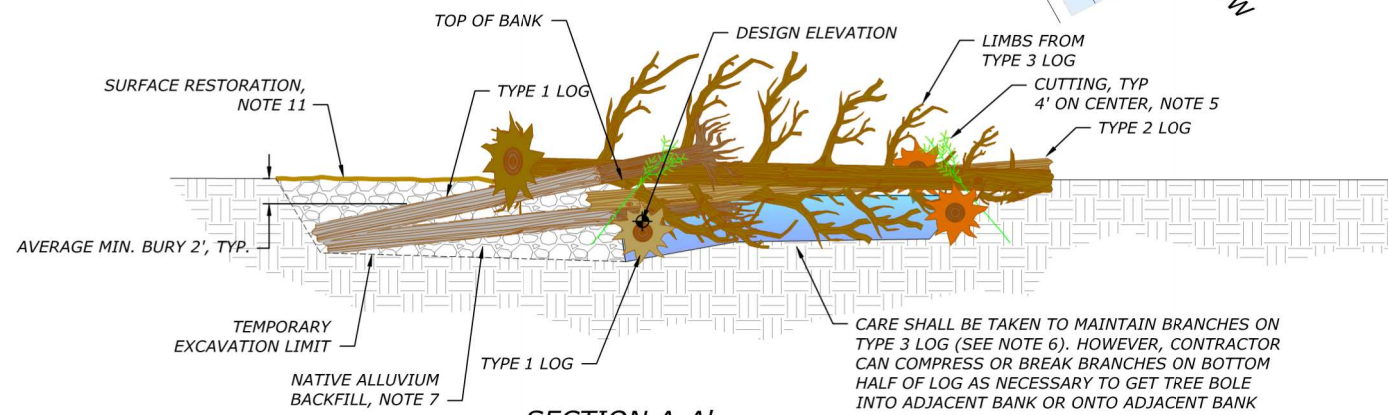

**SECTION A-A'**

**NOTES:**

1. INSTALL STRUCTURE AT LOCATION IDENTIFIED ON PLAN AND PROFILE DRAWINGS.
2. THE EXACT LOCATION OF STRUCTURE SHALL BE LOCATED PRIOR TO INSTALLATION FOR APPROVAL BY THE CONTRACTING OFFICER.
3. ROUGH GRADING OF CHANNEL SHALL BE COMPLETE PRIOR TO CONSTRUCTION OF STRUCTURE INCLUDING RIFFLE CONSTRUCTION AND PLACEMENT OF BAR MATERIAL.
4. SEE STRUCTURE SCHEDULE FOR NUMBER OF STRUCTURES, LOCATIONS, LOGS, AND ASSOCIATED MATERIAL QUANTITIES.
5. ALL CUT ENDS OF LOGS THAT WILL BE EXPOSED UPON COMPLETION OF STRUCTURE SHALL BE MARRED PRIOR TO OR UPON COMPLETION OF INSTALLATION. THE CONTRACTOR SHALL USE AN EXCAVATOR, OR OTHER HEAVY EQUIPMENT TO TEAR APART WOOD FIBERS AT THE CUT END OF THE LOG TO CREATE THE APPEARANCE OF A LOG THAT HAS NATURALLY BROKEN APART.
6. TYPE 3 LOG SHALL BE HANDLE DIRECTLY TO REDUCE LOSS OF LIMBS, FOLIAGE, ETC.. IF MORE THAN 15% OF TREE BRANCHES ARE REMOVED OR DAMAGED DURING HANDLING THE CONTRACTOR SHALL REPLACE AT NOT COST TO THE CONTRACTING AGENCY.
7. RACKING AND SLASH MATERIAL SHALL BE INCORPORATED INTO THE STRUCTURE WHILE PLACING LAYERS SUCH THAT IT IS WOVEN INTO STRUCTURE IN BETWEEN PLACED LOGS, FILLING VOIDS, ETC. AT EACH STEP THROUGHOUT CONSTRUCTION AS DIRECTED BY THE CONTRACTING OFFICER.
8. BACKFILL USING NATIVE EXCAVATED MATERIAL UNLESS NATIVE MATERIAL IS UNSUITABLE. UNSUITABLE MATERIAL CLASSIFIES AS A CLAY, SILT OR SAND. PLACE BACKFILL AS STRUCTURE IS CONSTRUCTED IN 1-FOOT MAXIMUM LIFTS. COMPACT EACH LIFT USING MECHANICAL EQUIPMENT SUCH AS AN EXCAVATOR BUCKET OR EQUIPMENT TRACKING MAKING CERTAIN TO NOT DAMAGE OR CHANGE THE ELEVATION OF THE STRUCTURE MATERIAL DURING COMPACTION.
9. WHEN UTILIZING EXISTING VEGETATION AS PASSIVE ANCHORS THERE SHALL BE AT A MINIMUM A WILLOW CLUMP ON THE DOWNSTREAM SIDE, BUT PREFERABLY ON THE UPSTREAM SIDE AS WELL.
10. LOG PLACEMENT MAY BE ADJUSTED IN THE FIELD BY THE CONTRACTING OFFICER TO PROVIDE VARIABILITY FROM STRUCTURE TO STRUCTURE.
11. SEE DRAWING L1 AND SPECIFICATIONS FOR PLANTING AND SEEDING REQUIREMENTS.

**STRUCTURE SEQUENCING**

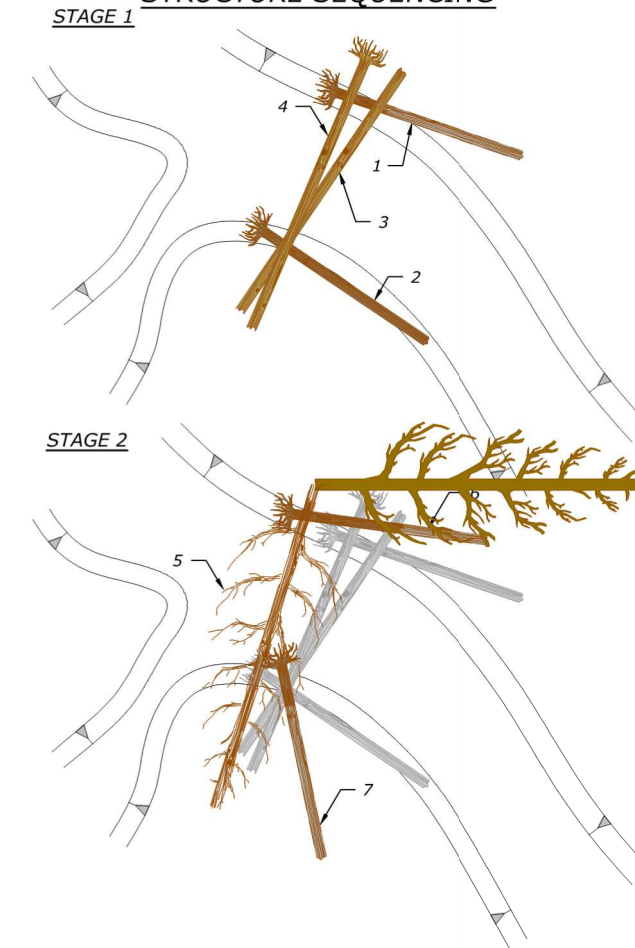

**STAGE 1**

**STAGE 2**

**HS-4: BLEEDER JAM**

Log Type	Size (DBH)	Min. Length (ft)	Rootwad	Branches	Quantity
Type 1	14" - 20"	30'	Yes	No	4
Type 2	14" - 20"	30'	No	No	1
Type 3	13" - 22"	40'	Yes	No	1
Type 5					1
Racking	4" - 12"	15'	--	Optional	9
Slash (CY)	1" - 4"	5'	--	Yes	5
Live Stakes (EA)	1/4" - 1"	6'	--	No	20

WORKING DRAFT  
FOR REVIEW AND  
REVISION

DATE: JULY, 2025  
DESIGNED: MP, IB, JE, ZS, SB  
APPROVED: JE

DRAWING NAME  
**DETAILS**  
  
HS-4 - BLEEDER JAM

DRAWING NO.  
**D7**  
SHEET 81 OF 94

FILE: R:\PROJECTS\LOWER GRANDE RONDE\_HUC65\CHESNIMNUS\_CREEK\NTS\CAD\PRODUCTION\CHESNIMNUS-NTS-DETAILS.DWG SAVED BY: SAM.BOX PLOT DATE: 7/30/2025 7:24 PM

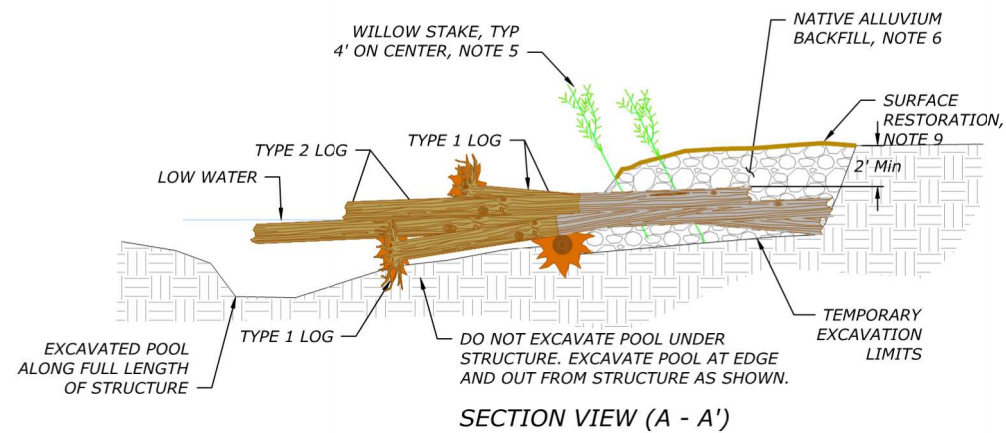
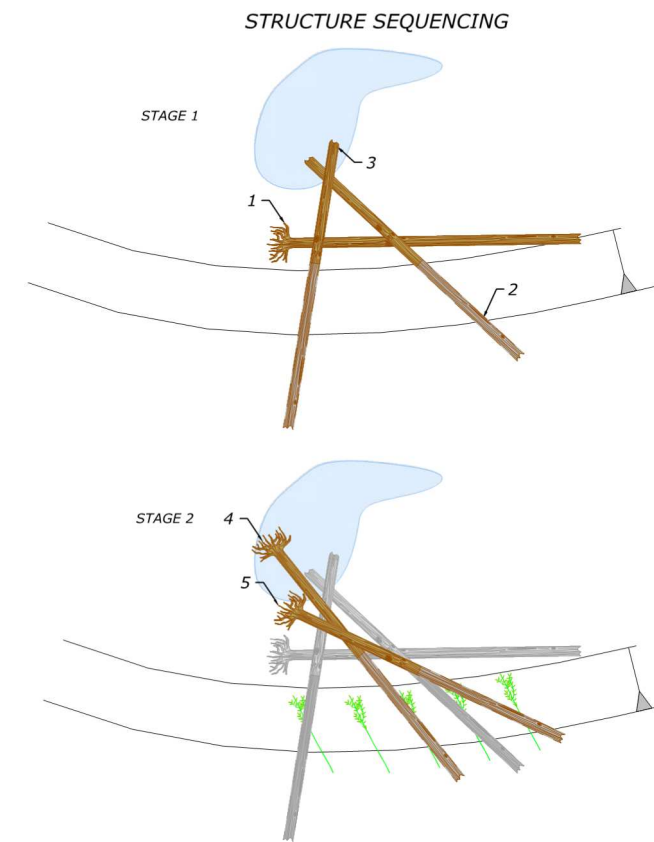
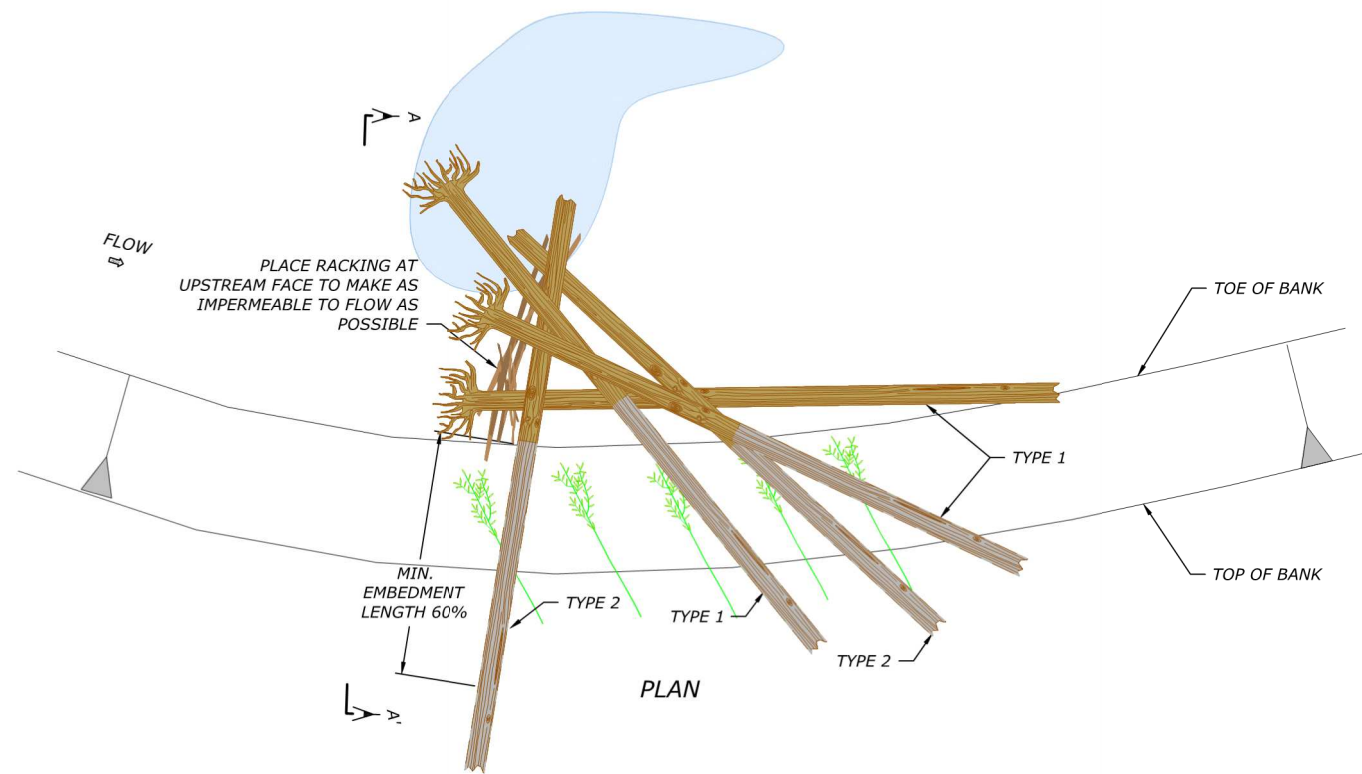

**NOTES:**

- INSTALL STRUCTURES AT LOCATIONS IDENTIFIED IN THE PLANS. THE EXACT LOCATION OF EACH STRUCTURE SHALL BE LOCATED PRIOR TO INSTALLATION FOR APPROVAL BY THE CONTRACTING OFFICER.
- WHERE POOL EXCAVATION IS NOT SPECIFIED IN THE GRADING PLAN, THE C.O. MAY DIRECT EXCAVATION OF A SCOUR POOL. IF A SCOUR POOL IS REQUIRED EXCAVATE A 2' DEEP POOL ADJACENT TO THE STRUCTURE AND EXTEND POOL OUT PAST ROOTWAD EXTENDING INTO CHANNEL.
- ROUGH GRADING OF CHANNEL SHALL BE COMPLETE PRIOR TO CONSTRUCTION OF STRUCTURE INCLUDING RIFFLE CONSTRUCTION AND PLACEMENT OF BAR MATERIAL.
- RACKING, SLASH, AND LIVE STAKES SHALL BE INCORPORATED INTO THE STRUCTURE WHILE PLACING LAYERS SUCH THAT IT IS WOVEN INTO STRUCTURE IN BETWEEN PLACED LOGS, FILLING VOIDS, ETC. AT EACH STEP THROUGHOUT CONSTRUCTION AS DIRECTED BY THE CONTRACTING OFFICER.
- LIVE STAKES SHALL BE INSTALLED PRIOR TO AND/OR DURING BACKFILLING TO ENSURE A MINIMUM OF 1-FT SUBMERGENCE IN GROUND WATER. LIVE STAKES SHALL HAVE CONTINUOUS CONTACT WITH SOIL ALONG THE LENGTH OF THE STAKE LEAVING NO VOIDS.
- BACKFILL USING NATIVE EXCAVATED MATERIAL UNLESS NATIVE MATERIAL IS UNSUITABLE. UNSUITABLE MATERIAL CLASSIFIES AS A CLAY, SILT OR SAND. PLACE BACKFILL AS THE STRUCTURE IS CONSTRUCTED IN 1-FOOT MAXIMUM LIFTS. COMPACT EACH LIFT USING MECHANICAL EQUIPMENT SUCH AS AN EXCAVATOR BUCKET OR EQUIPMENT TRACKING MAKING CERTAIN TO NOT DAMAGE OR CHANGE THE ELEVATION OF THE STRUCTURE MATERIAL DURING COMPACTION.
- ALL EXPOSED ENDS OF LOGS SHALL BE BROKEN/MARRED AND NOT SAW CUT TO APPEAR NATURAL.
- LOG PLACEMENT MAY BE ADJUSTED IN THE FIELD BY THE CONTRACTING OFFICER TO PROVIDE VARIABILITY FROM STRUCTURE TO STRUCTURE.
- SEE DRAWING L1 AND SPECIFICATIONS FOR PLANTING AND SEEDING REQUIREMENTS.

WORKING DRAFT  
FOR REVIEW AND  
REVISION

DATE: JULY, 2025  
DESIGNED: MP, IB, JF, ZS, SB  
APPROVED: JF

DRAWING NAME  
DETAILS

HS-5 - CONSTRUCTION  
JAM

DRAWING NO.  
D8  
SHEET 82 OF 94

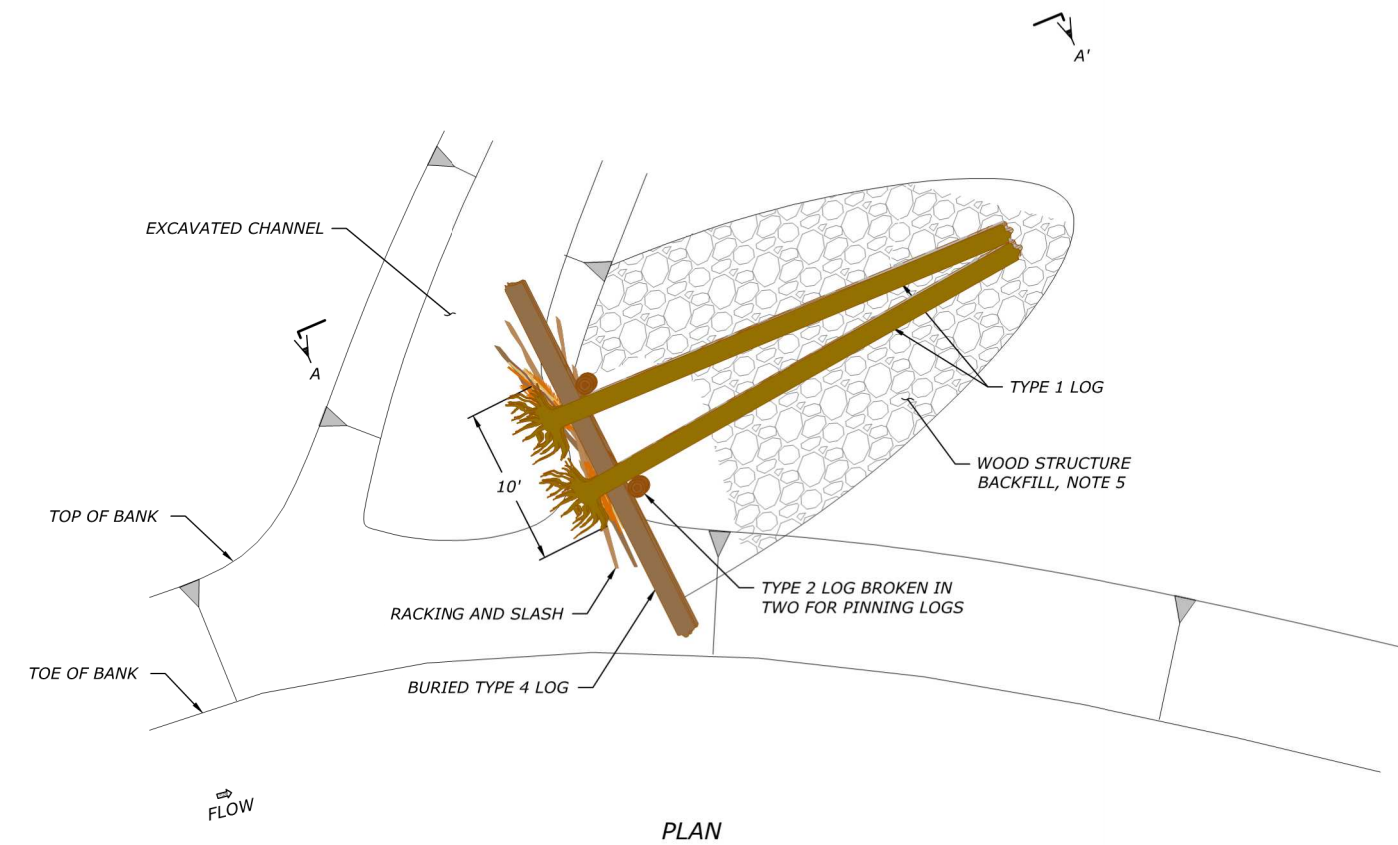

STRUCTURE SEQUENCING

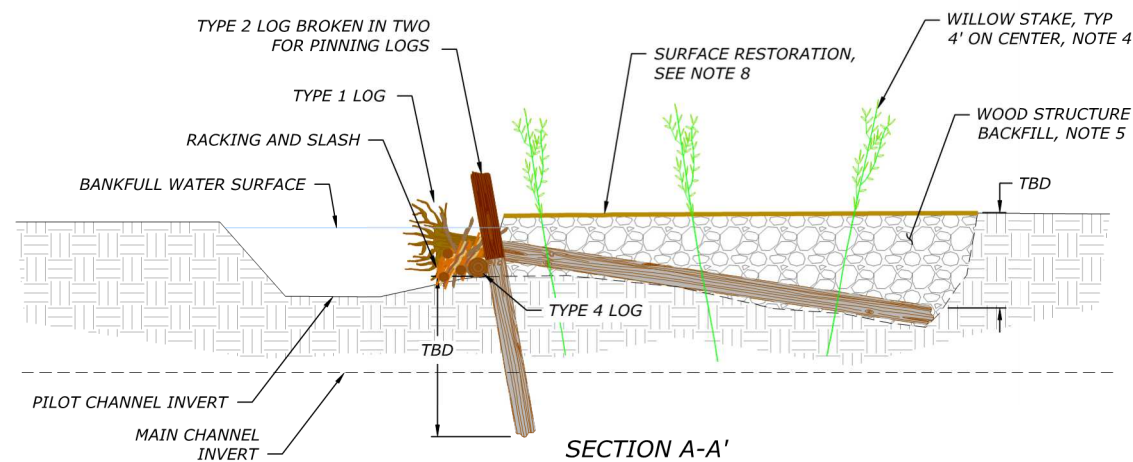
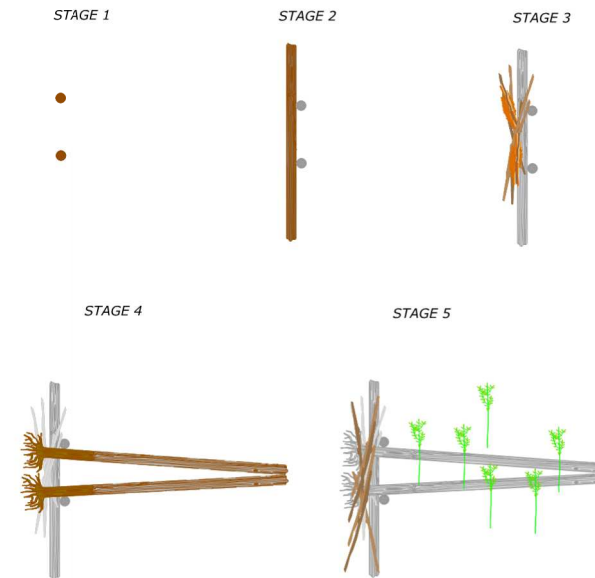

NOTES:

- INSTALL STRUCTURES AT LOCATIONS IDENTIFIED IN THE PLANS. THE EXACT LOCATION OF EACH STRUCTURE SHALL BE STAKED PRIOR TO INSTALLATION FOR APPROVAL BY THE CONTRACTING OFFICER.
- ROUGH GRADING OF PILOT CHANNEL SHALL BE COMPLETE PRIOR TO INSTALLATION OF LOGS.
- RACKING, SLASH, AND LIVE STAKES SHALL BE INCORPORATED INTO THE STRUCTURE BY WEAVING IT IN BETWEEN PLACED LOGS, FILLING VOIDS, ETC. AT EACH STEP THROUGHOUT CONSTRUCTION AS DIRECTED BY THE CONTRACTING OFFICER.
- LIVE STAKES SHALL BE INSTALLED PRIOR TO AND/OR DURING BACKFILLING TO ENSURE A MINIMUM OF 1-FT SUBMERGENCE IN GROUND WATER. LIVE STAKES SHALL HAVE CONTINUOUS CONTACT WITH SOIL ALONG THE LENGTH OF THE STAKE LEAVING NO VOIDS.
- BACKFILL USING SPECIFIED WOOD STRUCTURE BACKFILL MATERIAL. NATIVE EXCAVATED MATERIAL MAY BE USED AS WOOD STRUCTURE BACKFILL MATERIAL IF IT MEETS THE REQUIRED GRADATION. PLACE BACKFILL IN 1-FOOT MAXIMUM LIFTS. COMPACT EACH LIFT USING MECHANICAL EQUIPMENT SUCH AS AN EXCAVATOR BUCKET OR EQUIPMENT TRACKING MAKING CERTAIN TO NOT DAMAGE OR CHANGE THE ELEVATION OF THE STRUCTURE.
- ALL EXPOSED ENDS OF LOGS SHALL BE BROKEN AND NOT SAW CUT TO APPEAR NATURAL.
- LOG PLACEMENT MAY BE ADJUSTED IN THE FIELD BY THE CONTRACTING OFFICER TO PROVIDE VARIABILITY FROM STRUCTURE TO STRUCTURE.
- SEE DRAWING L1 AND SPECIFICATIONS FOR PLANTING AND SEEDING REQUIREMENTS

HS-6: SMALL APEX JAM

Log Type	Size (DBH)	Min. Length (ft)	Rootwad	Branches	Quantity
Type 1	14" - 20"	30'	Yes	No	2
Type 2	14" - 20"	30'	No	No	1
Type 4	12" - 14"	20'	No	No	1
Racking	4" - 12"	15'	--	Optional	10
Slash (CY)	1" - 4"	5'	--	Yes	10
Live Stakes (EA)	1/4" - 1"	6'	--	No	20

WORKING DRAFT  
FOR REVIEW AND  
REVISION

DATE: JULY, 2025  
DESIGNED: MP, IB, JF, ZS, SB  
APPROVED: JF

DRAWING NAME  
DETAILS

HS-6 - SMALL APEX JAM

DRAWING NO.  
D9  
SHEET 83 OF 94

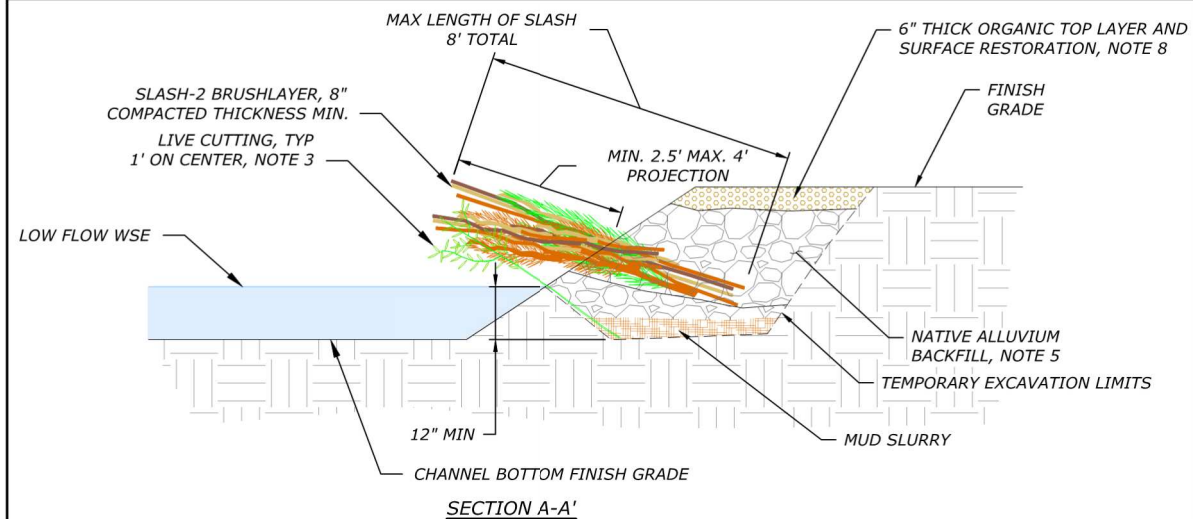

SECTION A-A'

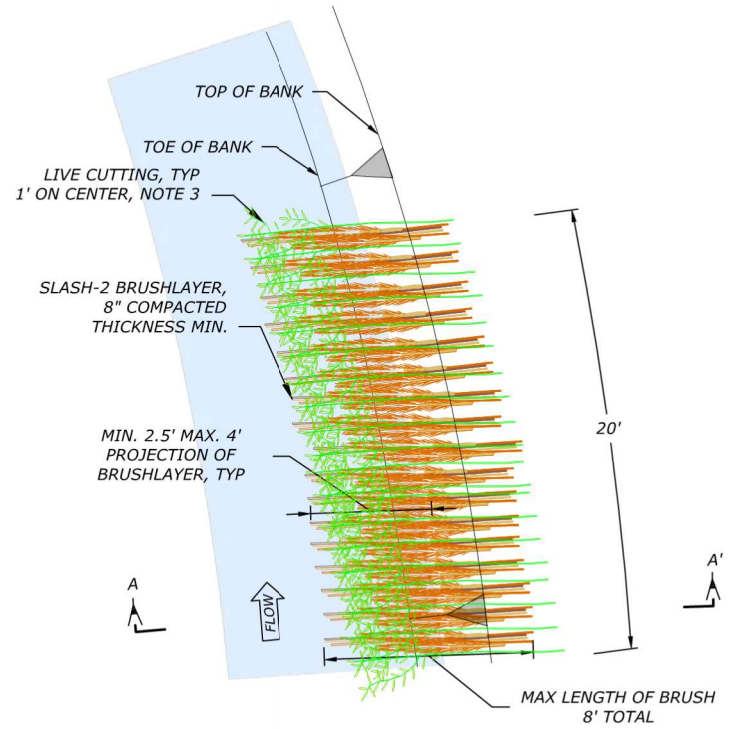

PLAN VIEW

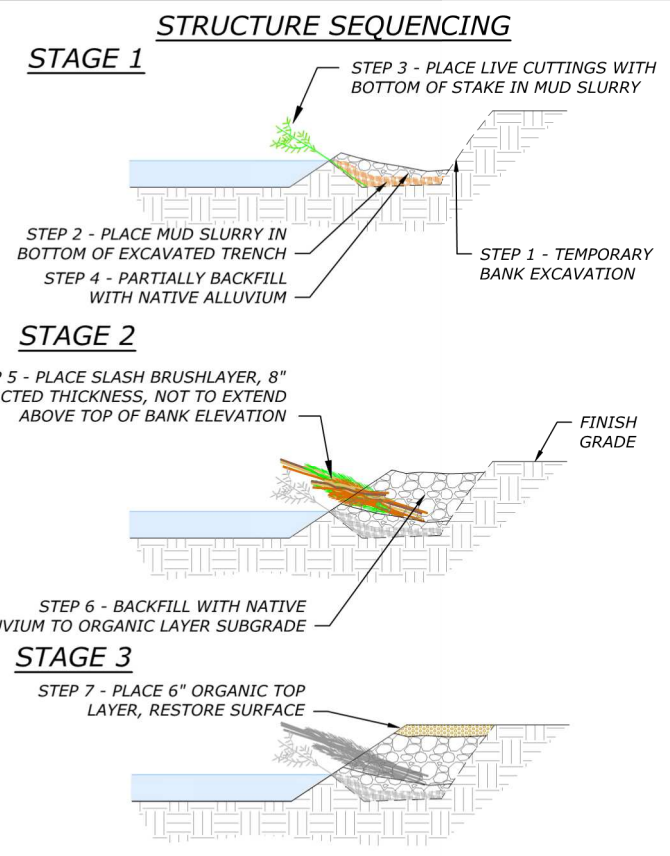

STAGE 1: MUD SLURRY IN BOTTOM OF EXCAVATED TRENCH WITH LIVE CUTTINGS PLACED.



EXAMPLE: COMPLETED BRUSH BANK

- NOTES:**
1. COMPLETE FINISH GRADING OF CHANNEL BOTTOM AND ROUGH GRADING OF BANK INCLUDING RIFFLE CONSTRUCTION AND PLACEMENT OF BAR MATERIALS PRIOR TO INSTALLING BRUSH BANK.
  2. LOCATE TOE OF SLOPE AND EXCAVATE TEMPORARY TRENCH STARTING AT THE ANTICIPATED LOW FLOW WATER SURFACE (SEE PLAN AND PROFILES FOR WATER SURFACE ELEVATIONS).
  3. INSTALL LIVE CUTTINGS AT A SPACING OF 1' ON CENTER A MINIMUM OF 1' BELOW GROUNDWATER OR ADJACENT CHANNEL INVERT WHICHEVER IS SHALLOWER. LIVE CUTTINGS SHALL HAVE CONTINUOUS SOIL TO STEM CONTACT ALONG THE LENGTH OF THE CUTTING LEAVING NO VOIDS.
  4. PLACE A 6-12" THICK MUD SLURRY INTO TRENCH TO PROVIDE GOOD MATERIAL FOR SOIL TO STEM CONTACT.
  5. PLACE SLASH-2 MATERIAL FROM THE ELEVATION OF THE LOW WATER SURFACE ELEVATION TO FORM A COMPACTED 8" THICK LAYER. PLACE SLASH MATERIAL IN LAYERS WITH GREATER THAN 50% OF INDIVIDUAL PIECES ALIGNED PERPENDICULAR TO FLOW WITH A MINIMUM OF 2.5' EMBEDMENT.
  6. FILL VOIDS OF SLASH MATERIAL BY SPRINKLING NATIVE ALLUVIUM BACKFILL OVER THE BURIED PORTION OF SLASH MATERIAL PER THE DETAIL AND LIGHTLY TAMP USING EXCAVATOR BUCKET AND WATER.
  7. BACKFILL OVER LIVE CUTTINGS AND SLASH MATERIAL BY PLACING NATIVE ALLUVIUM FILL IN 6" LIFTS AND TAMP WITH EXCAVATOR BUCKET TO FILL ANY ADDITIONAL VOIDS IN SLASH MATERIAL AND TO ENSURE GOOD STEM TO SOIL CONTACT OF LIVE CUTTINGS. CONTINUE TO PLACE ADDITIONAL NATIVE ALLUVIUM FILL AS NECESSARY TO ACHIEVE SUBGRADE OF ORGANIC LAYER TOP DRESSING.
  8. INSTALL TOP 6" THICK LAYER OF ORGANIC MATERIAL, UNCOMPACTED.
  9. SLASH GREATER THAN 8' SHALL BE BROKEN OR CUT TO MEET INSTALL INTENT WITHOUT RUNNING OVER VOLUME OF SLASH ESTIMATE.
  10. SEE DRAWING L1 AND SPECIFICATIONS FOR PLANTING AND SEEDING REQUIREMENTS.

**BRUSH BANK MATERIAL SCHEDULE (PER 20 LF OF BANK TREATMENT)**

LOG TYPE	DIAMETER (IN)	LENGTH (FT)	ROOTWAD	MIN ROOTWAD DIAMETER (FT)	BRANCHES	QUANTITY/ STRUCTURE
RACKING - 2	4"-12"	15-25	OPTIONAL	NA	YES	3 EA
SLASH	1" - 4"	5-15	NA	NA	YES	12 CY
LIVE CUTTINGS	> 3/4"	6-8	NA	NA	NO	32 EA

1. IF LIVE CUTTINGS QUANTITY IS FOR DORMANT INSTALLATION, QUANTITY SHALL BE DOUBLED IF INSTALLED APRIL 21 TO OCTOBER 10.

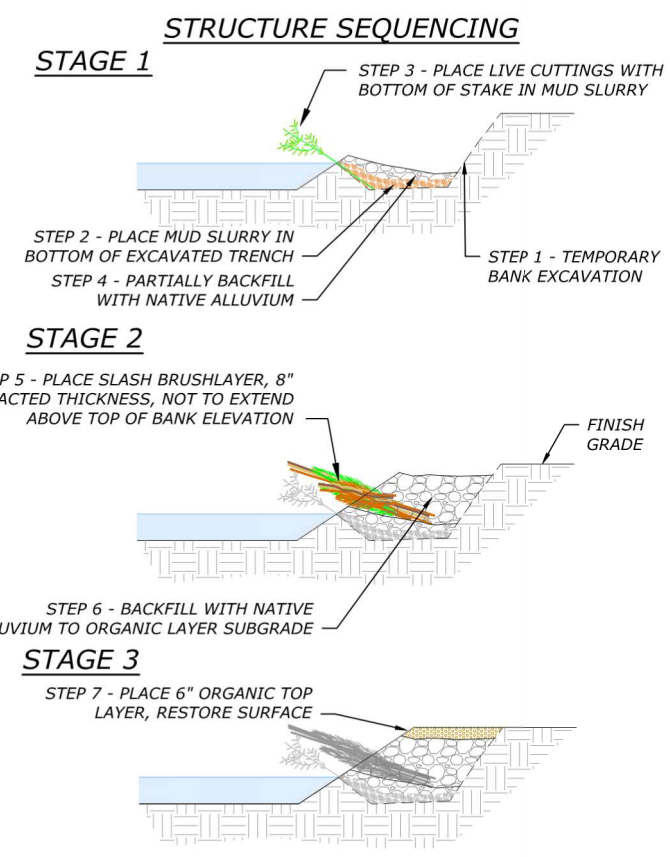
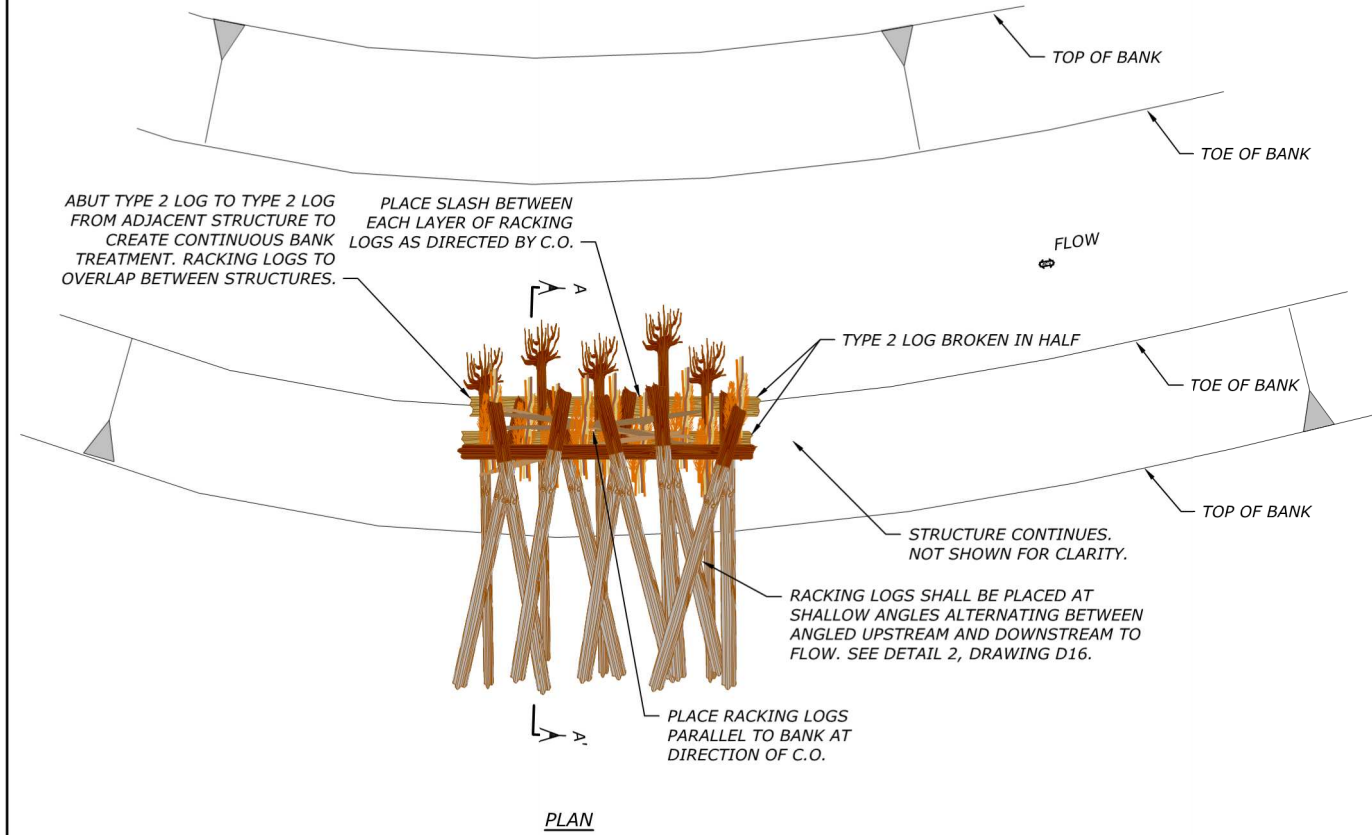

- NOTES:**
1. ROUGHENED EDGE BANK TREATMENT SHALL BE CONSTRUCTED AT LOCATIONS AS SHOWN ON THE PLANS. THE EXACT LOCATION OF EACH OCCURRENCE OF BANK ROUGHNESS SHALL BE LOCATED BY THE CONTRACTOR AND APPROVED BY THE C.O. PRIOR TO CONSTRUCTING A PARTICULAR OCCURRENCE.
  2. ALL EXPOSED ENDS OF KEY LOGS AND RACKING LOGS SHALL BE BROKEN. ALL EXPOSED CLEAN CUT ENDS OF LOGS WILL REQUIRE THE CONTRACTOR TO REPLACE WITH A BROKEN END AT NO ADDITIONAL EXPENSE.

- STEPS:**
1. TYPE 2 LOG (FOOTER) SHALL BE PLACED SO ITS UPSTREAM END RESTS ON THE STREAM BED (UP TO 1/2 DIAMETER BURIED TO ACCOMODATE VARIED BANK HEIGHTS) ALONG THE TOE OF THE BANK. BACKFILL AND COMPACT AROUND FOOTER LOG WITH COMPACTED FILL.
  2. RACKING-2 LOGS (WITH ROOTWADS) SHALL BE INSTALLED ON TOP OF THE TYPE 2 LOG. ROOTWADS SHALL BE PLACED OVER TOP OF FOOTER LOG WITH ROOTWAD AS CLOSE TO BANK AS POSSIBLE AND AS DIRECTED BY C.O. IF BUILDING SHORT ROUGHENED EDGE, SKIP TO STEP 4.
  3. REPEAT STEPS 1 AND 2 AT THE DIRECTION OF C.O. TO BUILD TALL ROUGHENED EDGE.
  4. PLACE GENERAL FILL OVER PLACED MATERIALS AND COMPACT TO CREATE AN APPROXIMATE 45-DEGREE SURFACE FOR INSTALLATION OF BRUSH BANK TREATMENT AT THE ANTICIPATED LOW WATER ELEVATION. LOW WATER ELEVATION CAN BE ESTIMATED FROM PLAN AND PROFILE DRAWINGS. A PROPOSED LOW WATER ELEVATION SURFACE CAN BE PROVIDED TO THE CONTRACTOR UPON REQUEST FOR GPS USE.
  5. INSTALL BRUSH BANK PER DRAWING D11.
  6. PLACE RACKING LOGS PARALLEL TO BANK AND ALONG BANK AT TOP OF STRUCTURE, PIN WITH TWO RACKING LOGS WITH EXPOSED ENDS DOWNSTREAM TO FLOW. ENSURE THAT RACKING LOGS ARE NOT TOO STEEPLY VERTICALLY ANGLED FROM FRONT TO BACK BY PLACING FILL AT BACKSIDE AS NECESSARY.
  7. BACKFILL TO TOP OF ANGLED LOGS WITH COMPACTED FILL.
  8. PLACE SLASH ALONG TOP OF BACKFILL AT BANK EDGE AS DIRECTED BY C.O.
  9. BACKFILL TO FINISH. BACKFILL SHALL BE PLACED IN MAXIMUM 1-FT LIFTS AND COMPACTED.
  10. SEE DRAWING L1 AND SPECIFICATIONS FOR PLANTING AND SEEDING REQUIREMENTS

ROUGHENED EDGE MATERIAL SCHEDULE (PER 15 LF OF BANK TREATMENT)						
LOG TYPE	DIAMETER (IN)	LENGTH (FT)	ROOTWAD	MIN ROOTWAD DIAMETER (FT)	BRANCHES	QUANTITY/STRUCTURE
TYPE 2	13" - 22"	30 - 40	NO	NA	NO	1 EA
RACKING - 1	4" - 12"	15 - 25	YES	2.5	YES	5 EA
RACKING - 2	4" - 12"	15 - 25	OPTIONAL	NA	YES	4 EA
SLASH	1" - 4"	5-15	NA	NA	YES	15 CY
LIVE CUTTINGS	> 3/4"	6 - 8	NA	NA	NO	16 EA

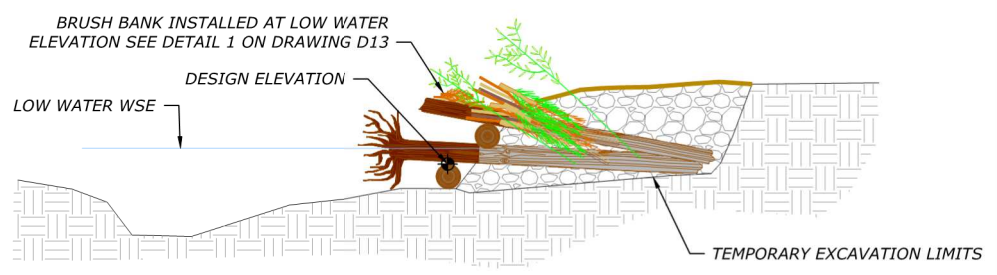

1. QUANTITIES SHOWN IN THE TABLES INCLUDE QUANTITIES ASSOCIATED WITH THE BRUSH BANK PORTION OF THESE TREATMENTS.
2. C.O. MAY REQUEST PLACEMENT OF ADDITIONAL MATERIAL BASED ON BANK HEIGHT AND EXPOSURE OF UNSUITABLE MATERIAL.
3. IF LIVE CUTTINGS QUANTITY IS FOR DORMANT INSTALLATION, QUANTITY SHALL BE DOUBLED IF INSTALLED APRIL 21 TO OCTOBER 10.

**WORKING DRAFT FOR REVIEW AND REVISION**

DATE: JULY, 2025  
 DESIGNED: MP, IB, JF, ZS, SB  
 APPROVED: JF

DRAWING NAME  
**DETAILS**  
**ROUGHENED EDGE**  
 DRAWING NO.  
**D12**  
 SHEET 86 OF 94

FILE: R:\PROJECTS\LOWER GRANDE RONDE\_HUC65\CHESNIMNUS\_CREEK\_NPT\CAD\PRODUCTION\CHESNIMNUS\_NPT\DETAILS.DWG SAVED BY: SAM.BOX PLOT DATE: 7/30/2025 7:24 PM